

Regularity for the optimal compliance problem with length penalization

Antonin Chambolle*

Jimmy Lamboley[†]

Antoine Lemenant[‡]

Eugene Stepanov^{§¶}

October 26, 2016

Abstract

We study the regularity and topological structure of a compact connected set S minimizing the “compliance” functional with a length penalization. The compliance is, here, the work of the force applied to a membrane which is attached along the set S .

This shape optimization problem, which can be interpreted as that of finding the best location for attaching a membrane subject to a given external force, can be seen as an elliptic PDE version of the minimal average distance problem.

We prove that minimizers in the given region consist of a finite number of smooth curves which meet only at triple points with angles of 120 degrees, contain no loops, and possibly touch the boundary of the region only tangentially. The proof uses, among other ingredients, some tools from the theory of free discontinuity problems (monotonicity formula, flatness improving estimates, blow-up limits), but adapted to the specific problem of min-max type studied here, which constitutes a significant difference with the classical setting and may be useful also for similar other problems.

*CMAP, Ecole Polytechnique, CNRS, 91128 Palaiseau Cedex, France

[†]Université Paris-Dauphine, PSL Research University, UMR 7534, CEREMADE, Place du Maréchal de Lattre de Tassigny, 75775 Paris, France

[‡]Université Paris Diderot - LJLL CNRS UMR 7598 - Paris 7 75205 Paris Cedex 13, France

[§]St.Petersburg Branch of the Steklov Mathematical Institute of the Russian Academy of Sciences, Fontanka 27, 191023 St.Petersburg,Russia and Department of Mathematical Physics, Faculty of Mathematics and Mechanics, St. Petersburg State University, Universitetskij pr. 28, Old Peterhof, 198504 St.Petersburg, Russia and ITMO University, Russia

[¶]This work was partially supported by the projects ANR-12-BS01-0007 OPTIFORM and ANR-12-BS01-0014-01 GEOMETRYA financed by the French Agence Nationale de la Recherche (ANR). The authors acknowledge the support of the project MACRO (Modèles d'Approximation Continue de Réseaux Optimaux), funded by the Programme Gaspard Monge pour l'Optimisation of EDF and the Fondation Mathématiques Jacques Hadamard. The fourth author also acknowledges the support of the St.Petersburg State University grants #6.60.1355.2016 and #6.38.223.2014, the Russian government grant #074-U01 and the RFBR grant #14-01-00534.

Contents

1	Introduction and main results	3
2	Preliminaries	7
2.1	Notation	7
2.2	Estimate of u_Σ	8
2.3	Existence	8
3	Estimates of the variations of the compliance	9
3.1	Localization lemma	9
3.2	Monotonicity formula and decay of energy	10
3.3	Estimate of $ \mathcal{C}(\Sigma) - \mathcal{C}(\Sigma') $	12
4	First qualitative properties	14
4.1	Absence of loops	14
4.2	Ahlfors regularity	16
5	Flatness and small energy implies C^1 regularity	17
5.1	Control of the energy when Σ is flat	17
5.2	Density estimates	23
5.3	Flatness estimates	28
6	Blow-up limits of minimizers and first consequences	33
6.1	Convergence of blow-up sequences for interior points	33
6.2	Two compactness estimates	36
6.3	Flat points are C^1 -points	38
6.4	Chord-arc estimate and connectedness of blow-up limits	39
7	Dual formulation and classification of blow-up limits	43
7.1	Dual formulation	43
7.2	Minimization problem for the blow-up limit	45
7.3	Another formulation and characterization of global minimizers	48
7.4	Blow-up limit at a boundary point	49
8	Conclusion and full regularity	52
8.1	Finite number of curves	52
8.2	Further regularity	55
A	Auxiliary results	55

1 Introduction and main results

Consider a bounded open set $\Omega \subset \mathbb{R}^2$. Let $\Sigma \subset \bar{\Omega}$ be a closed set, and for $f \in L^2(\Omega)$ and $u \in H_0^1(\Omega \setminus \Sigma)$ denote

$$E(u) := \frac{1}{2} \int_{\Omega \setminus \Sigma} |\nabla u|^2 dx - \int_{\Omega} f u dx.$$

Letting $u_{\Sigma} \in H_0^1(\Omega \setminus \Sigma)$ stand for the unique minimizer of $E(\cdot)$ over $H_0^1(\Omega \setminus \Sigma)$, it is well-known that

$$-\Delta u_{\Sigma} = f \tag{1}$$

in the weak sense in $\Omega \setminus \Sigma$. From the physical point of view we can think of Ω as a membrane, and Σ as the “glue line” attaching it to some fixed base (i.e. preventing the displacement). Then u_{Σ} is the displacement of the membrane with the boundary fixed subject to the force field f . The compliance of the membrane can then be defined as

$$\mathcal{C}(\Sigma) := -E(u_{\Sigma}) = \frac{1}{2} \int_{\Omega \setminus \Sigma} |\nabla u_{\Sigma}|^2 dx = \frac{1}{2} \int_{\Omega} f u_{\Sigma} dx,$$

the equivalence of the two above expressions for \mathcal{C} being due to (1). It can be seen as a measure of how much the membrane resists to the force field f , and is proportional to the work of the force. In this paper we study the following problem.

Problem 1.1. *Given $\lambda > 0$, find a set $\Sigma \subset \bar{\Omega}$ minimizing the functional \mathcal{F}_{λ} defined by*

$$\mathcal{F}_{\lambda}(\Sigma') := \mathcal{C}(\Sigma') + \lambda \mathcal{H}^1(\Sigma') = -E(u_{\Sigma'}) + \lambda \mathcal{H}^1(\Sigma')$$

among all closed connected sets $\Sigma' \subset \bar{\Omega}$.

A similar problem, previously introduced and studied in the literature (see e.g. [8, 5, 35]) is that of minimizing the compliance \mathcal{C} over closed connected sets Σ subject to the constraint on the length $\mathcal{H}^1(\Sigma) \leq \ell$ instead of the length penalization. In this paper we however concentrate our attention exclusively on the penalized Problem 1.1, which may be physically interpreted as follows: we are trying to find the best location Σ for the glue to put on a membrane in order to minimize the compliance of the latter, subject to the force f , while the penalization by $\lambda \mathcal{H}^1$ takes into account, for instance, the quantity (or cost) of the glue.

The existence of minimizers of Problem 1.1 follows in a more or less standard way from Blaschke, Šverák, and Gołab theorems, see Proposition 2.5 (or [8]).

A problem similar to Problem 1.1 has been studied in [36], where the compliance $\mathcal{C}(\Sigma)$ has been replaced by $\lambda_1(\Omega \setminus \Sigma)$, the first eigenvalue of the Laplace operator with Dirichlet condition on $\Sigma \cup \partial\Omega$, in a constrained version $\mathcal{H}^1(\Sigma) \leq \ell$. In [36], the asymptotic behavior of solutions to this problem when $\ell \rightarrow +\infty$ has been identified. On the other hand, the regularity of minimizers is not known for this problem. Since $\lambda_1(\Omega \setminus \Sigma)$ is still an energy of elliptic type, we believe that the technics introduced in this paper for the compliance could also serve to study its eigenvalue version, though do not pursue this analysis here.

Another version of shape optimization problem similar to Problem 1.1 may be obtained substituting the standard Laplacian by the p -Laplace operator. In this case, letting $p \rightarrow \infty$, one obtains [8, Theorem 3] in the limit the so-called average distance minimization problem of purely geometric nature

$$\min_{\Sigma \subset \bar{\Omega} \text{ closed connected}} \int_{\Omega} \text{dist}(x, \Sigma) d\mu + \lambda \mathcal{H}^1(\Sigma).$$

This problem is related to a Monge-Kantorovitch problem with a “free Dirichlet region” which was introduced as a model for an optimal urban traffic network [6, 9]. The topological and

geometric properties of minimizers of this problem (mostly in its constrained version but also in the easier penalized one) were studied by several authors (see [24] for a review on this problem, and [7, 28, 32, 10, 23, 30, 34] for related results on this and similar problems).

Problem 1.1 is much different from the average distance minimization problem, and to certain extent is closer to the Mumford-Shah problem. We will indeed prove at the end of this paper that it is in a sense dual to the Mumford-Shah problem, and a certain amount of tools used in this paper (monotonicity formula, scheme of proof for the C^1 result) is inspired by the arguments developed for the Mumford-Shah functional (we refer to [2, 11, 21] for reviews on the latter). Here, we show that the minimizers are locally smooth inside Ω . This is in sharp contrast with the average distance problem: in fact, for the latter Slepčev [31] (see also [26]) has shown that minimizers are, in general, not C^1 and using his construction one may find minimizers with infinite and possibly not closed set of points with lack of regularity [25].

Main results

The following theorem sums up the main results of this paper.

Theorem 1.2. *Let $\Omega \subset \mathbb{R}^2$ be a C^1 domain (i.e. an open bounded connected set with the boundary locally, up to rotation, the graph of a C^1 function), and $\lambda \in (0, \infty)$. If $f \in L^p(\Omega)$ with $p > 2$, then every solution Σ of Problem 1.1 has the following properties.*

PART I: QUALITATIVE PROPERTIES.

- (i) Σ contains no loops (homeomorphic images of S^1), hence $\mathbb{R}^2 \setminus \Sigma$ is connected.
- (ii) Σ is Ahlfors regular.
- (iii) Σ is a chord-arc set, i.e. it satisfies

$$d_{\Sigma}(x, y) \leq C|x - y|, \quad (2)$$

for some constant $C > 0$, where d_{Σ} denotes the geodesic distance in Σ .

PART II: REGULARITY.

- (iv) Σ consists of a finite number of embedded curves, possibly intersecting at “triple points” where the curves are meeting by 3 at 120 degrees angles. In particular, it has finite number of endpoints and finite number of branching points, all of which are triple points as described.
- (v) Such curves are locally $C^{1,\alpha}$ regular for some $\alpha \in (0, 1)$ inside Ω and possibly touch $\partial\Omega$ only tangentially. Moreover, if Ω is a convex domain, then they are locally $C^{1,\alpha}$ in $\bar{\Omega}$.
- (vi) If, further, $f \in H^1(\Omega)$ (so that automatically $f \in L^p(\Omega)$ for any $p > 2$), then the curves of Σ are locally $C^{2,\alpha}$ inside Ω for any $\alpha \in (0, 1)$, and if f , moreover, is locally $C^{k,\beta}$ regular for some $k \in \mathbb{N}$ and $\beta \in (0, 1)$ then the latter curves are locally $C^{k+3,\beta}$. If furthermore f is analytic, then the curves are locally analytic.

We emphasize that (i) and (iv)-(v) are probably the most interesting items of this result, while (ii) and (iii) might at first glance look technical. However, besides being interesting on their own, more remarkably, the results of Part I are needed to prove Part II. Let us stress moreover that several of the announced results still hold without assuming C^1 regularity of $\partial\Omega$. For instance, for a generic bounded open $\Omega \subset \mathbb{R}^2$ we show in fact that every minimizer Σ of Problem 1.1 satisfies (i) and (ii), i.e. has no loops and is Ahlfors regular, and for every open $\Omega' \Subset \Omega$, the estimate (2) still holds for $\{x, y\} \subset \Sigma \cap \Omega'$ (with the constant C depending on Ω');

moreover, Σ has a finite number of branching points and endpoints in $\Sigma \cap \Omega'$, all the branching points are triple points where the curves are meeting by 3 at angles of 120 degrees, while the curves composing $\Sigma \cap \Omega'$ are locally $C^{1,\alpha}$ regular.

With the developed technique at hand, it would be also possible to get some finer results for just Lipschitz domains, as, for instance, the fact that the optimal set Σ will never touch a convex corner of $\partial\Omega$, but we do not pursue this analysis in details.

We finally mention that the $C^{1,\alpha}$ regularity up to the tip of an endpoint, or up to the branching point for a triple point, is not proven in this paper. We only know that any blow-up sequence is converging to the global minimizer of corresponding type at the limit. However, concerning the triple points, it is quite likely that one could adapt our ε -regularity result (Theorem 6.4) to obtain a similar statement, as David did in [11, Section 53] for Mumford-Shah minimizers.

Theorem 1.2 is the concatenation of several results contained in the paper. Namely, (i) is Theorem 4.1, (ii) is Theorem 4.3, (iii) is Proposition 6.7. Assertions (iv) and (v) are given by Theorem 8.1, in particular, the finite number of curves comes from Theorem 8.6, the characterization of branching by 120 degrees comes from the classification of blow-up limits (Proposition 7.9) together with the uniqueness of the type of the blow-up (Proposition 8.4). The property (v) for a generic (that is, not necessarily convex) Ω , i.e. the local $C^{1,\alpha}$ regularity of the curves has two ingredients, namely, the classification of blow-up limits (Proposition 7.9) which together with Proposition 8.4 says that any point which is not a triple point neither an endpoint is necessarily a “flat” point, i.e. blows-up as a line), and then Theorem 6.4 which says that Σ is $C^{1,\alpha}$ around any “flat” points. The fact that Σ touches $\partial\Omega$ tangentially is a consequence of Theorem 7.13 and Proposition 7.14. The case of Ω convex in (v) is Remark 8.3. Finally, (vi) is Proposition 8.8.

Basic techniques and background idea

The proof of the local $C^{1,\alpha}$ regularity result is contained in Sections 5 and 7. The main strategy is inspired by the regularity theory for the Mumford-Shah functional in dimension 2, more precisely by the approach of Bonnet [3] and David [11]. The rough idea that first comes in mind is to show that every minimizer Σ of Problem 1.1 is an *almost minimizer* for the length, i.e. to prove that for any competitor Σ' satisfying $\Sigma \Delta \Sigma' \subset B_r$, where B_r stands for a ball of radius $r > 0$, one has

$$\mathcal{H}^1(\Sigma \cap B_r) \leq \mathcal{H}^1(\Sigma' \cap B_r) + Cr^{1+\alpha},$$

and then to apply the regularity theory for almost minimal sets.

In our situation, the error term $Cr^{1+\alpha}$ may only come from the energy (or, equivalently, compliance) part of the functional, namely, we need to prove an estimate of type

$$|\mathcal{C}(\Sigma) - \mathcal{C}(\Sigma')| \leq Cr^{1+\alpha}, \quad \text{if } \Sigma \Delta \Sigma' \subset B_r.$$

To obtain the latter we have to overcome several difficulties which are due to essential differences between Problem 1.1 and more classical free boundary or free discontinuity problems. The first one is a substantially nonlocal behavior of the compliance functional, in the sense that small perturbations of Σ affects the potential u_Σ in the whole Ω . This can be overcome by a simple cut-off argument (Lemma 3.1). It shows that if Σ' is a competitor for Σ in B_r , then the defect of minimality is controlled by the inequality

$$|\mathcal{C}(\Sigma) - \mathcal{C}(\Sigma')| \leq C \int_{B_r} |\nabla u_{\Sigma'}|^2 dx.$$

Here, the right hand side depends on the competitor Σ' , which leads us to introduce the quantity

$$\omega_\Sigma(x, r) := \max_{\Sigma' \text{ connected}; \Sigma' \Delta \Sigma \subset \bar{B}_r(x)} \left(\frac{1}{r} \int_{B_r(x)} |\nabla u_{\Sigma'}|^2 dx \right),$$

and we arrive at the estimate

$$|\mathcal{C}(\Sigma) - \mathcal{C}(\Sigma')| \leq Cr\omega_\Sigma(x, r).$$

To obtain $C^{1,\alpha}$ regularity, one has to prove that $\omega_\Sigma(x, r) \leq Cr^\alpha$ for some $\alpha > 0$. This is done via a classical monotonicity formula, which is a version of the one of Bonnet [3], but adapted for Dirichlet boundary conditions. It implies a suitable decay for $\omega_\Sigma(x, r)$, provided that Σ is flat enough in the neighborhood of x . On the other hand the flatness decays suitably fast provided that ω_Σ is small enough. In other words, we cannot apply directly the theory of almost minimal sets but we have to reproduce some of its arguments, with the additional difficulty that we have to control both the quantity ω_Σ and flatness of Σ at the same time. All this leads to an “ ε -regularity” result (Corollary 5.18). At the end we can bootstrap all the estimates and the $C^{1,\alpha}$ regularity follows.

To get the full regularity result (i.e. to show that every minimizer Σ consists of finite number of smooth injective curves), we perform a blow-up analysis. Again, the main difficulty comes from the nonlocal behavior of the compliance functional. To bypass it, we consider the dual formulation of Problem 1.1 (Proposition 7.2), proving that Problem 1.1 is equivalent to the following one:

$$\min_{(\sigma, \Sigma) \in \mathcal{B}} \frac{1}{2} \int_{\Omega} |\sigma|^2 dx + \mathcal{H}^1(\Sigma), \quad \text{where}$$

$$\mathcal{B} := \{(\sigma, \Sigma) : \Sigma \subset \bar{\Omega} \text{ compact connected}, \sigma \in L^2(\Omega, \mathbb{R}^2), \operatorname{div} \sigma = f \text{ in } \mathcal{D}'(\Omega \setminus \Sigma)\}.$$

The latter problem is now localizable. As a matter of fact, it turns out that this dual problem is very close to the Mumford-Shah problem, and more remarkably, the dual formulation of the minimizing problem satisfied by the blow-up limits is exactly the same as the characterization of global minimizers for Mumford-Shah problem in [3]. This gives a possibility to characterize completely the possible blow-up limits and conclude the proof of full regularity. This is done in Section 7. Note however, that the blow-up at the boundary of $\partial\Omega$ is much different than what usually happens in the Mumford-Shah problem. Here the blow-up limits at the boundary are tangent to the boundary, whereas for the Mumford-Shah functional they are transversal.

Let us furthermore mention that we first prove several other qualitative properties of minimizers, like Ahlfors-regularity, absence of loops, chord-arc estimate (Part I of Theorem 1.2). It is worth mentioning that, curiously enough, all of these properties are needed to characterize the blow-up limits. More precisely, one of the key ingredients that leads to the classification of the global minimizers for the Mumford-Shah functional is the fact that the blow-up limits are connected in the limit, as required by Bonnet [3] to get the classification of blow-up limits. Although here we deal with a priori connected sets, in general, the blow-up of a connected set may not be connected in the limit, and this is why one needs to use the optimality. To this aim, we prove that every minimizer Σ of Problem 1.1 is a chord-arc set (Proposition 6.7). It is not difficult to see then that the blow-up limit of a chord-arc set is connected. A similar chord-arc estimate has been already proven for each connected component of a Mumford-Shah minimizer, but the proof presented here for the compliance minimizers is much different: here we need to preserve connectedness on competitors. Our strategy is as follows. Let us look closer at the rough idea of proving that a minimizer does not contain loops. The argument is by cutting the loop at a flat point by a piece of set of size r , and estimate the loss in the compliance term in terms of $r^{1+\alpha}$, provided that we have found a suitable point where to cut. The proof of (2) is a sort of quantitative version of this argument: if x and y are very close to each others and the curve connecting them in Σ is going far away, then one can cut this curve at some place where it is flat, and add the little segment connecting x to y to preserve connectedness. To perform it, one needs the radius of the ball where Σ is flat to be controlled from below, uniformly with

respect to the distance from x to y . This is obtained from the uniform rectifiability of Σ , which follows from the Ahlfors-regularity of the latter (Theorem 4.3).

2 Preliminaries

2.1 Notation

We introduce the following notation.

- For $\{x, y\} \subset \mathbb{R}^2$, $|x|$ denotes the Euclidean norm and $d(x, y) := |x - y|$ the Euclidean distance, $x \cdot y$ the usual inner product.
- $(\mathbf{e}_1, \mathbf{e}_2)$ denotes the canonical basis of \mathbb{R}^2 .
- For $D \subset \mathbb{R}^2$, $\mathbf{1}_D$ is the characteristic function of D , $D^c := \mathbb{R}^2 \setminus D$, \overline{D} and ∂D are the closure and the topological boundary of D respectively, $\mathcal{H}^1(D)$ is the 1-dimensional Hausdorff measure of D , $\text{diam } D$ the diameter of D , and $\text{dist}(x, D) := \inf\{d(x, y) : y \in D\}$ whenever $x \in \mathbb{R}^2$.
- We let $B_r(x) := \{y \in \mathbb{R}^2 : d(x, y) < r\}$ stand for the open ball of radius $r \in (0, \infty)$ and center $x \in \mathbb{R}^2$; if $\alpha > 0$ then we use also the notation $\alpha B_r(x) := B_{\alpha r}(x)$.
- $d_H(A, B)$ is the Hausdorff distance between the sets A and B defined by

$$d_H(A, B) := \max\left(\sup_{x \in A} \text{dist}(x, B), \sup_{x \in B} \text{dist}(x, A)\right).$$

Let now $\Omega \subset \mathbb{R}^2$.

- If Ω is measurable, then $L^p(\Omega)$ stands for the Lebesgue space of p -integrable real functions for $p \in [1, +\infty)$ and measurable essentially bounded functions for $p = +\infty$, $\|\cdot\|_p$ standing for its standard norm and p' for the conjugate exponent $1/p + 1/p' = 1$; $L^p(\Omega, \mathbb{R}^2)$ is the respective Lebesgue space of functions with values in \mathbb{R}^2 ; $L^p_{loc}(\Omega)$ is the space of functions u such that $u \in L^p(K)$ for all compact $K \subset \Omega$. The convergence in $L^p_{loc}(\Omega)$ means the convergence for the norm $\|\cdot\|_p$ on every compact $K \subset \Omega$.

If Ω is open, then

- $\mathcal{K}(\Omega)$ denotes the set of all compact and connected sets $\Sigma \subset \overline{\Omega}$;
- $C_0^\infty(\Omega)$ stands for the class of infinitely differentiable functions with compact support in Ω ;
- $C^k(\Omega)$ (resp. $C^{k, \alpha}(\Omega)$) stands for the class of k times continuous differentiable functions (resp. k times differentiable with α -Hölder continuous k -th derivative) in Ω , where $k \in \mathbb{N}$, $\alpha \in (0, 1)$;
- $\mathcal{D}'(\Omega)$ stands for the usual space of distributions in Ω ;
- $\text{Lip}(\overline{\Omega})$ stands for the class of all Lipschitz maps $f: \overline{\Omega} \rightarrow \mathbb{R}$;
- $H^1(\Omega)$ is the standard Sobolev space of functions $u \in L^2(\Omega)$ having (distributional) derivative in $L^2(\Omega)$; $H^1_{loc}(\Omega)$ is its local version akin to $L^p_{loc}(\Omega)$;

- $H_0^1(\Omega)$ stands for the usual Sobolev space defined by the closure of $C_0^\infty(\Omega)$ for the norm $\|u\|_{H_0^1(\Omega)} := \int_\Omega |\nabla u|^2 dx$; if necessary, the functions in $H_0^1(\Omega)$ will be silently assumed to be extended to the whole \mathbb{R}^n by zero over Ω^c . This gives a natural embedding of $H_0^1(\Omega)$ into $H^1(\mathbb{R}^n)$;
- Given $\Omega' \subset \Omega$ and $\Sigma \in \mathcal{K}(\Omega)$ we will also denote by

$$H_{0,\Sigma}^1(\Omega' \setminus \Sigma) = \bigcup_{g \in H_0^1(\Omega \setminus \Sigma)} (g + H_0^1(\Omega' \setminus \Sigma)).$$

An open, bounded, and connected $\Omega \subset \mathbb{R}^2$ will be called a C^1 domain, if $\partial\Omega$ is locally up to rotation the graph of a C^1 function.

We extensively use the standard terminology on connected metric spaces, see, e.g. [19]. In particular, an *arc* for us is an injective curve.

2.2 Estimate of u_Σ

Let $\Omega \subset \mathbb{R}^2$ be an open set. When $\Sigma \subset \bar{\Omega}$ is closed, then $\Omega \setminus \Sigma$ is open, and it is well-known that if $f \in L^2(\Omega)$, then there is a unique function u_Σ that minimizes E over $H_0^1(\Omega \setminus \Sigma)$. The dependence of u and hence of compliance on Σ is related to the fact that a 1-dimensional set in \mathbb{R}^2 has a non-trivial capacity: in fact, if Σ has zero Hausdorff dimension, then $\mathcal{C}(\Sigma) = \mathcal{C}(\emptyset)$.

In this paper, we need the following estimate, which is a direct consequence of [17, Theorem 8.16].

Proposition 2.1. *If $f \in L^p(\Omega)$ for some $p > 2$ and Σ is a closed subset of $\bar{\Omega}$, then u_Σ is bounded with*

$$\|u_\Sigma\|_\infty \leq C \|f\|_p. \quad (3)$$

for some $C = C(p, |\Omega|) > 0$.

Remark 2.2. Under the conditions of the above Proposition 2.1 we have further that

$$\begin{aligned} \|\nabla u_\Sigma\|_2^2 &= 2\mathcal{C}(u_\Sigma) \leq 2\mathcal{C}(\emptyset) = 2 \int_\Omega |\nabla u_\emptyset|^2 dx \\ &= 2 \int_\Omega u_\emptyset f dx \leq C(p, |\Omega|) \|f\|_p |\Omega|^{1/p'} \quad \text{by Hölder inequality and (3)}. \end{aligned} \quad (4)$$

2.3 Existence

Here we state a particular case of Šverák's theorem, which will be used several times in this paper.

Theorem 2.3 (Šverák [33]). *Let Ω an open bounded set in \mathbb{R}^2 , and $f \in L^2(\Omega)$. Let $\{\Sigma_n\}_n$ be a sequence of connected sets in Ω , converging to $\Sigma \subset \bar{\Omega}$ in the Hausdorff distance. Then*

$$u_{\Sigma_n} \xrightarrow[n \rightarrow \infty]{} u_\Sigma \quad \text{strongly in } H^1(\Omega).$$

Remark 2.4. Notice that a byproduct of Šverák's theorem is the so called Mosco-convergence of $H_0^1(\Omega \setminus \Sigma_n)$ that will be used later in the paper. More precisely, for every $u \in H^1(\Omega \setminus \Sigma)$ there exists a sequence $\{u_n\} \subset H_0^1(\Omega \setminus \Sigma_n)$ such that $u_n \rightarrow u$ strongly in $H^1(\Omega)$, and moreover any sequence $\{v_n\} \subset H_0^1(\Omega \setminus \Sigma_n)$ with $v_n \rightharpoonup v$ weakly in $H^1(\Omega)$ satisfies $v \in H_0^1(\Omega \setminus \Sigma)$ (see [18, Proposition 3.5.4]).

The following simple assertion gives existence of solutions to the penalized optimal compliance problem.

Proposition 2.5. *Problem 1.1 admits a minimizer.*

Proof. Let Σ_n be a minimizing sequence for Problem 1.1. From Blaschke's selection principle [2, Theorem 6.1] there exists a subsequence converging in the Hausdorff distance to some closed $\Sigma \subset \bar{\Omega}$. By Theorem 2.3 u_{Σ_n} converges strongly in $H^1(\Omega)$ to u_Σ and Gołab's theorem [14, Theorem 3.18] gives the lower-semicontinuity of \mathcal{H}^1 , which implies that Σ must be a minimizer. \square

Remark 2.6. In [8] the assumption $f \geq 0$ is added in the statement of existence but it is in fact unnecessary.

Remark 2.7. If we drop the connectedness assumption on Σ , then the existence of a minimizer for \mathcal{F}_λ fails. Indeed, it is not difficult to construct an example of a (highly disconnected) set $\Sigma \subset \Omega$ with $\mathcal{H}^1(\Sigma)$ arbitrary small which spreads into Ω so that u_Σ has very small energy, leading to

$$\inf_{\Sigma \subset \Omega, \text{closed}} \mathcal{F}_\lambda(\Sigma) = 0.$$

3 Estimates of the variations of the compliance

Our goal in this section is to obtain an estimate of the variation of the compliance between Σ and Σ' when $\Sigma \Delta \Sigma'$ is localized, without assuming any regularity for Σ and Σ' .

3.1 Localization lemma

We first prove the following localization lemma.

Lemma 3.1. *Let $f \in L^2(\Omega)$, Σ and Σ' be closed subsets of $\bar{\Omega}$, and let $x_0 \in \mathbb{R}^2$. We consider $0 < r_0 < r_1$ and assume $\Sigma' \Delta \Sigma \subset B_{r_0}(x_0)$. Then for every $\varphi \in \text{Lip}(\mathbb{R}^2)$ such that $\varphi = 1$ over $B_{r_1}^c(x_0)$, $\varphi = 0$ over $B_{r_0}(x_0)$, and $\|\varphi\|_\infty \leq 1$ on \mathbb{R}^2 , one has*

$$E(u_\Sigma) - E(u_{\Sigma'}) \leq \int_{B_{r_1}(x_0)} u_{\Sigma'} f (1 - \varphi) dx + \int_{B_{r_1}(x_0)} u_{\Sigma'}^2 |\nabla \varphi|^2 dx + \int_{B_{r_1}(x_0)} u_{\Sigma'} \varphi \nabla u_{\Sigma'} \cdot \nabla \varphi dx.$$

Proof. Since $u_{\Sigma'} \varphi \in H_0^1(\Omega \setminus \Sigma)$ and u_Σ is a minimizer of E over $H_0^1(\Omega \setminus \Sigma)$, we have

$$E(u_\Sigma) \leq E(u_{\Sigma'} \varphi),$$

and hence,

$$\begin{aligned} E(u_\Sigma) - E(u_{\Sigma'}) &\leq E(u_{\Sigma'} \varphi) - E(u_{\Sigma'}) \leq \frac{1}{2} \int_{\Omega} |\nabla(u_{\Sigma'} \varphi)|^2 dx - \int_{\Omega} u_{\Sigma'} \varphi f dx \\ &\quad - \frac{1}{2} \int_{\Omega} |\nabla u_{\Sigma'}|^2 dx + \int_{\Omega} u_{\Sigma'} f dx \\ &= \frac{1}{2} \int_{\Omega} |\nabla u_{\Sigma'}|^2 \varphi^2 dx + \frac{1}{2} \int_{\Omega} |\nabla \varphi|^2 u_{\Sigma'}^2 dx + \int_{\Omega} u_{\Sigma'} \varphi \nabla u_{\Sigma'} \cdot \nabla \varphi dx - \int_{\Omega} u_{\Sigma'} \varphi f dx \\ &\quad - \frac{1}{2} \int_{\Omega} |\nabla u_{\Sigma'}|^2 dx + \int_{\Omega} u_{\Sigma'} f dx \\ &= \frac{1}{2} \int_{\Omega} |\nabla u_{\Sigma'}|^2 \underbrace{(\varphi^2 - 1)}_{\leq 0} dx + \frac{1}{2} \int_{\Omega} |\nabla \varphi|^2 u_{\Sigma'}^2 dx + \int_{\Omega} u_{\Sigma'} (1 - \varphi) f dx \\ &\quad + \int_{\Omega} u_{\Sigma'} \varphi \nabla u_{\Sigma'} \cdot \nabla \varphi dx. \end{aligned}$$

Therefore, recalling that $\varphi = 1$ over $B_{r_1}^c(x_0)$, we conclude the proof. \square

Remark 3.2. Note that if $\Sigma' \subset \Sigma$, then

$$0 \leq E(u_\Sigma) - E(u_{\Sigma'}),$$

since $H_0^1(\Omega \setminus \Sigma) \subset H_0^1(\Omega \setminus \Sigma')$.

3.2 Monotonicity formula and decay of energy

The monotonicity of energy will be one of our main tools in the sequel. We start with a general statement which says that the maximum length for $\partial B_r \setminus \Sigma$ gives the power of decay for the function u_Σ . In what follows we assume that u_Σ is extended by zero outside Ω .

Lemma 3.3. *Let $\Sigma \subset \bar{\Omega}$ be a closed set, $f \in L^p(\Omega)$, where $p > 2$, and $x_0 \in \bar{\Omega}$. Let $0 \leq r_0 < r_1$, and $\gamma \in [\gamma_\Sigma(x_0, r_0, r_1), 2\pi] \setminus \{0\}$, where we denote*

$$\gamma_\Sigma(x_0, r_0, r_1) := \sup \left\{ \frac{\mathcal{H}^1(S)}{r} : r \in (r_0, r_1) \text{ and } S \text{ connected component of } \partial B_r(x_0) \setminus (\Sigma \cup \partial\Omega) \right\}, \quad (5)$$

We assume

$$(\Sigma \cup \partial\Omega) \cap \partial B_r(x_0) \neq \emptyset \text{ for all } r \in [r_0, r_1], \quad (6)$$

and finally we suppose that $1/p' > \pi/\gamma$. Then the function

$$r \in [r_0, r_1] \mapsto \frac{1}{r^\alpha} \int_{B_r(x_0)} |\nabla u_\Sigma|^2 dx + Cr^{\frac{2}{p'} - \alpha},$$

is nondecreasing, where $\alpha := 2\pi/\gamma$ and $C = C(|\Omega|, p, \|f\|_p, \gamma) > 0$.

Remark 3.4. In particular, setting $\gamma := 2\pi$ in the above Lemma, we get that the function

$$r \in [r_0, r_1] \mapsto \frac{1}{r} \int_{B_r(x_0)} |\nabla u_\Sigma|^2 dx + Cr^{\frac{2}{p'} - 1},$$

where $C = C(|\Omega|, p, \|f\|_p) > 0$, is nondecreasing, once x_0 satisfies (6).

Proof. We denote $u = u_\Sigma$ and extend u by zero outside Ω , so that $u \in H^1(\mathbb{R}^2)$. One has for a.e. $r \in (r_0, r_1)$, that

$$\begin{aligned} G(r) &:= \int_{B_r(x_0)} |\nabla u|^2 dx \\ &= \int_{\partial B_r(x_0)} u \frac{\partial u}{\partial \nu} d\mathcal{H}^1 + \int_{B_r(x_0)} f u dx \quad \text{by Lemma A.3} \\ &\leq \int_{\partial B_r(x_0)} \frac{\delta}{2} u^2 d\mathcal{H}^1 + \int_{\partial B_r(x_0)} \frac{1}{2\delta} \left(\frac{\partial u}{\partial \nu} \right)^2 d\mathcal{H}^1 + \int_{B_r(x_0)} f u dx \end{aligned} \quad (7)$$

for every $\delta > 0$. By Poincaré inequality (Lemma A.1) that can be applied because of (6), we get

$$\int_{\partial B_r(x_0)} u^2 d\mathcal{H}^1 = \int_{\partial B_r(x_0) \setminus (\Sigma \cup \partial\Omega)} u^2 d\mathcal{H}^1 \leq \left(\frac{\gamma r}{\pi} \right)^2 \int_{\partial B_r(x_0) \setminus (\Sigma \cup \partial\Omega)} |\nabla_\tau u|^2 d\mathcal{H}^1,$$

Notice indeed that the trace of u on $\partial B_r(x_0)$ belongs to $H_0^1(\partial B_r(x_0) \setminus (\Sigma \cup \partial\Omega))$ for a.e. r . Thus choosing $\delta := \pi/(\gamma r)$, we get

$$\begin{aligned} G(r) &\leq \frac{1}{2} \frac{\gamma r}{\pi} \int_{\partial B_r(x_0)} \left(|\nabla_\tau u|^2 + \left(\frac{\partial u}{\partial \nu} \right)^2 \right) d\mathcal{H}^1 + \int_{B_r(x_0)} f u \, dx \\ &= \frac{\gamma}{2\pi} r \int_{\partial B_r(x_0)} |\nabla u|^2 d\mathcal{H}^1 + \int_{B_r(x_0)} f u \, dx \\ &= \frac{\gamma}{2\pi} r G'(r) + \int_{B_r(x_0)} f u \, dx. \end{aligned} \tag{8}$$

By Fubini's theorem, the function $r \mapsto G(r)$ is indeed absolutely continuous, and its derivative is a.e. equal to $r \mapsto \int_{\partial B_r(x_0)} |\nabla u|^2 d\mathcal{H}^1$.

Recalling that $u \in L^\infty(\Omega)$ by Proposition 2.1 and using the Hölder inequality together with (3) to estimate

$$\left| \int_{B_r(x_0)} f u \, dx \right| \leq C r^{2/p'}$$

with some constant $C > 0$ depending only on $\|f\|_p$, p , $|\Omega|$, we get

$$G(r) \leq \frac{\gamma}{2\pi} r G'(r) + C r^{2/p'}.$$

This differential inequality implies that the function

$$r \mapsto \frac{G(r)}{r^\alpha} + C_0 r^{\frac{2}{p'} - \alpha}$$

is nondecreasing, with

$$C_0 := \frac{C\alpha}{\frac{2}{p'} - \alpha} \quad \text{and} \quad \alpha = \frac{2\pi}{\gamma}$$

(notice that $\frac{2}{p'} - \alpha > 0$ under our assumptions). Indeed,

$$\begin{aligned} \frac{d}{dr} \left(\frac{G(r)}{r^\alpha} + C_0 r^{\frac{2}{p'} - \alpha} \right) &= \frac{G'(r)r^\alpha - G(r)\alpha r^{\alpha-1}}{r^{2\alpha}} + C\alpha r^{\frac{2}{p'} - \alpha - 1} \\ &= \frac{G'(r)r^\alpha - G(r)\alpha r^{\alpha-1} + C\alpha r^{\frac{2}{p'} + \alpha - 1}}{r^{2\alpha}} \\ &= \alpha \frac{\frac{1}{\alpha} G'(r)r - G(r) + C r^{\frac{2}{p'}}}{r^{\alpha+1}} \geq 0. \end{aligned}$$

□

In particular, for C^1 domains we obtain the following useful decay at the boundary.

Lemma 3.5. *Assume that Ω is a C^1 domain, let $\Sigma \subset \bar{\Omega}$ be a closed set and $p > 2$. Then there exist an $r_0 = r_0(\partial\Omega, |\Omega|, p, \|f\|_p) > 0$ and an $\eta = \eta(p) > 0$ such that*

$$\int_{B_r(x)} |\nabla u_\Sigma|^2 \, dx \leq C_1 \left(\frac{r}{r_0} \right)^{1+\eta} \quad \text{for all } x \in \partial\Omega \text{ and for all } r \in (0, r_0),$$

where C_1 is a positive constant depending only on $|\Omega|$, p , $\|f\|_p$.

Proof. Since $p > 2$, one has $1/p' > 1/2$, so that one can find $\gamma_p < 2\pi$ such that

$$\frac{1}{p'} > \frac{\pi}{\gamma_p} > \frac{1}{2}.$$

Now since $\partial\Omega$ is locally C^1 and compact, and since $\gamma_p > \pi p' > \pi$, there exists a threshold r_Ω depending on $\partial\Omega$ (and also on γ_p) such that $\partial\Omega$ is flat enough in all the balls $B_r(x)$ for $r \leq r_\Omega$, uniformly in $x \in \partial\Omega$, in the sense that $\gamma_\Sigma(x, 0, r_0) \leq \gamma_p$ for all $x \in \partial\Omega$. Thus Lemma 3.3 is valid with x , 0 and r_Ω instead of x_0 , r_0 and r_1 respectively, giving for all $x \in \partial\Omega$ and $0 < r < r_0 < r_\Omega$ the estimate

$$\begin{aligned} \frac{1}{r^\alpha} \int_{B_r(x)} |\nabla u_\Sigma|^2 dx + Cr^{\frac{2}{p'} - \alpha} &\leq \frac{1}{r_0^\alpha} \int_{B_{r_\Omega}(x)} |\nabla u_\Sigma|^2 dx + Cr_0^{\frac{2}{p'} - \alpha} \\ &\leq \frac{1}{r_0^\alpha} \|\nabla u_\Sigma\|_2^2 + Cr_0^{\frac{2}{p'} - \alpha}, \end{aligned}$$

where $C = C(|\Omega|, p, \|f\|_p)$ and $\alpha = 2\pi/\gamma_p$. Multiplying by r^α , defining $\eta := \alpha - 1 = (2\pi/\gamma_p) - 1$, and estimating $\|\nabla u_\Sigma\|_2$ by Remark 2.2, we get

$$\int_{B_r(x)} |\nabla u_\Sigma|^2 dx \leq C_1 \left(\frac{r}{r_0}\right)^{1+\eta} + C_2 r_0^{\frac{2}{p'} - \eta + 1} r^{1+\eta} \quad \text{for all } x \in \partial\Omega \text{ and for all } r \in (0, r_0),$$

with positive constants C_1 and C_2 depending on $|\Omega|$, p , $\|f\|_p$ and γ_p only. The claim follows now up to obvious renaming of the constant C_1 , if one chooses r_0 so as to satisfy together with $r_0 \in (0, r_\Omega)$ also the estimate

$$C_2 r_0^{\frac{2}{p'}} \leq C_1,$$

which implies

$$C_1 \left(\frac{r}{r_0}\right)^{1+\eta} \leq C_2 r_0^{\frac{2}{p'} - \eta + 1} r^{1+\eta}.$$

□

3.3 Estimate of $|\mathcal{C}(\Sigma) - \mathcal{C}(\Sigma')|$

We collect now all the necessary estimates on minimizers of E over $H_0^1(\Omega \setminus \Sigma)$ in the following statement.

Lemma 3.6. *Let $\Sigma \subset \bar{\Omega}$ be a closed connected set, $f \in L^p(\Omega)$, where $p > 2$, and $x_0 \in \mathbb{R}^2$. Let r_0, r_1 satisfy*

$$\Sigma \cap B_{r_0}(x_0) \neq \emptyset, \quad \Sigma \setminus B_{r_1}(x_0) \neq \emptyset. \quad (9)$$

Then for any $r \in [r_0, r_1/2]$, for any $\varphi \in \text{Lip}(\mathbb{R}^2)$ such that $\|\varphi\|_\infty \leq 1$ and $\varphi = 1$ in $B_{2r}^c(x_0)$, $\varphi = 0$ in $B_r(x_0)$ and $\|\nabla\varphi\|_\infty \leq 1/r$, the following assertions hold.

(i) *There exists a $C > 0$ depending only on $|\Omega|$, p , $\|f\|_p$ such that:*

$$\left| \int_{B_{2r}(x_0)} u_\Sigma f (1 - \varphi) dx \right| \leq Cr^{\frac{2}{p'}}. \quad (10)$$

(ii) *There exists a universal constant $C > 0$ such that:*

$$\left| \int_{B_{2r}(x_0)} u_\Sigma^2 |\nabla\varphi|^2 dx \right| \leq C \int_{B_{2r}(x_0) \setminus B_r(x_0)} |\nabla u_\Sigma|^2 dx. \quad (11)$$

(iii) There exists a universal constant $C > 0$ such that:

$$\left| \int_{B_{2r}(x_0)} u_{\Sigma} \varphi \nabla u_{\Sigma} \cdot \nabla \varphi \, dx \right| \leq C \int_{B_{2r}(x_0)} |\nabla u_{\Sigma}|^2 \, dx. \quad (12)$$

Proof. The estimate (10) (i.e. claim (i)) comes directly from the Hölder inequality together with Proposition 2.1.

To prove (ii), we can use Poincaré inequality (Lemma A.2), since $\Sigma \cap \overline{B_r}(x_0) \neq \emptyset$ and $\Sigma \setminus B_{2r}(x_0) \neq \emptyset$. We obtain in this way

$$\int_{B_{2r}(x_0) \setminus B_r(x_0)} u_{\Sigma}^2 \, dx \leq 16r^2 \int_{B_{2r}(x_0) \setminus B_r(x_0)} |\nabla u_{\Sigma}|^2 \, dx, \quad (13)$$

and using the fact that $|\nabla \varphi| \leq \frac{1}{r} \cdot \mathbf{1}_{B_{2r}(x_0) \setminus B_r(x_0)}$, we directly get (11) from (13).

It remains to prove (iii). To this aim, we estimate

$$\begin{aligned} \left| \int_{B_{2r}(x_0)} u_{\Sigma} \varphi \nabla u_{\Sigma} \cdot \nabla \varphi \, dx \right| &\leq \frac{1}{r} \int_{B_{2r}(x_0) \setminus B_r(x_0)} |u_{\Sigma}| \cdot |\nabla u_{\Sigma}| \, dx \\ &\leq \frac{1}{r} \left(\int_{B_{2r}(x_0) \setminus B_r(x_0)} u_{\Sigma}^2 \, dx \right)^{\frac{1}{2}} \left(\int_{B_{2r}(x_0)} |\nabla u_{\Sigma}|^2 \, dx \right)^{\frac{1}{2}}, \end{aligned} \quad (14)$$

the latter by Hölder inequality. As in (13), from Poincaré inequality in the annulus $B_{2r}(x_0) \setminus B_r(x_0)$ (Lemma A.2) we get

$$\int_{B_{2r}(x_0) \setminus B_r(x_0)} u_{\Sigma}^2 \, dx \leq 16r^2 \int_{B_{2r}(x_0)} |\nabla u_{\Sigma}|^2 \, dx,$$

so that (14) becomes

$$\left| \int_{B_{2r}(x_0)} u_{\Sigma} \varphi \nabla u_{\Sigma} \cdot \nabla \varphi \, dx \right| \leq 4 \int_{B_{2r}(x_0)} |\nabla u_{\Sigma}|^2 \, dx, \quad (15)$$

as desired. \square

Proposition 3.7. Let $\Sigma \subset \overline{\Omega}$ be a closed connected set, $f \in L^p(\Omega)$, where $p > 2$, and $x_0 \in \Sigma$. Let r_0, r_1 satisfy

$$0 < 2r_0 < r_1 < \min(1, \text{diam}(\Sigma)/2),$$

and $\gamma \in [\gamma_{\Sigma}(x_0, r_0, r_1), 2\pi] \setminus \{0\}$ be such that $1/p' > \pi/\gamma$ (see (5) for the definition of γ_{Σ}). Then for any $r \in [r_0, r_1/2]$, and for any closed connected set $\Sigma' \subset \overline{\Omega}$ satisfying $\Sigma \Delta \Sigma' \subset B_r(x_0)$ we have

$$|\mathcal{C}(\Sigma') - \mathcal{C}(\Sigma)| = |E(u_{\Sigma'}) - E(u_{\Sigma})| \leq C \left(\frac{r}{r_1} \right)^{\frac{2\pi}{\gamma}}, \quad (16)$$

where $C > 0$ depends on $|\Omega|$, $\|f\|_p$, γ , p .

Proof. There exists a $\varphi \in \text{Lip}(\mathbb{R}^2)$ as in the statement of Lemma 3.6, i.e. such that $\|\varphi\|_{\infty} \leq 1$, $\varphi = 1$ over $B_{2r}^c(x_0)$, $\varphi = 0$ over $B_r(x_0)$ and $\|\nabla \varphi\|_{\infty} \leq 1/r$. From Lemma 3.1 (applied with r and $2r$ instead of r_0 and r_1 respectively), and the fact that $u_{\Sigma'} \in H_0^1(\Omega \setminus \Sigma')$, we have

$$\begin{aligned} E(u_{\Sigma'}) - E(u_{\Sigma}) &\leq \int_{B_{2r}(x_0)} u_{\Sigma} f (1 - \varphi) \, dx + \int_{B_{2r}(x_0) \setminus (\Sigma \cup \partial\Omega)} u_{\Sigma}^2 |\nabla \varphi|^2 \, dx \\ &\quad + \int_{B_{2r}(x_0) \setminus (\Sigma \cup \partial\Omega)} u_{\Sigma} \varphi \nabla u_{\Sigma} \cdot \nabla \varphi \, dx, \end{aligned} \quad (17)$$

and, interchanging Σ with Σ' ,

$$\begin{aligned} E(u_\Sigma) - E(u_{\Sigma'}) &\leq \int_{B_{2r}(x_0)} u_{\Sigma'} f(1 - \varphi) dx + \int_{B_{2r}(x_0) \setminus (\Sigma' \cup \partial\Omega)} u_{\Sigma'}^2 |\nabla\varphi|^2 dx \\ &\quad + \int_{B_{2r}(x_0) \setminus (\Sigma' \cup \partial\Omega)} u_{\Sigma'} \varphi \nabla u_{\Sigma'} \cdot \nabla\varphi dx. \end{aligned} \quad (18)$$

Observe that we can apply Lemma 3.3 and Lemma 3.6 for both Σ and Σ' . For Σ , we use the connectedness of Σ , the facts that $x_0 \in \Sigma$ and $r_1 < \text{diam}(\Sigma)/2$ to obtain (6) and (9). For Σ' we apply Lemma 3.3 and Lemma 3.6 with r instead of r_0 : indeed, $\Sigma \Delta \Sigma' \subset B_r(x_0)$ implies that (6) and (9) are also valid for Σ' for $[r, r_1]$ instead of $[r_0, r_1]$, and we notice that

$$\gamma_{\Sigma'}(x_0, r, r_1) = \gamma_\Sigma(x_0, r, r_1) \leq \gamma_\Sigma(x_0, r_0, r_1) \leq \gamma. \quad (19)$$

Therefore,

$$\begin{aligned} \frac{1}{r^\alpha} \int_{B_r(x_0)} |\nabla u_\Sigma|^2 dx &\leq \frac{1}{r_1^\alpha} \int_{B_{r_1}(x_0)} |\nabla u_\Sigma|^2 dx + Cr_1^{\frac{2}{p'} - \alpha} \\ &\leq \frac{1}{r_1^\alpha} \|\nabla u_\Sigma\|_2^2 + Cr_1^{\frac{2}{p'} - \alpha}, \end{aligned}$$

with $\alpha = 2\pi/\gamma$ and $C = C(|\Omega|, p, \|f\|_p, \gamma)$, and estimating $\|\nabla u_\Sigma\|_2$ by Remark 2.2, we get

$$\int_{B_r(x_0)} |\nabla u_\Sigma|^2 dx \leq \left(\frac{r}{r_1}\right)^\alpha (C_1 + Cr_1^{\frac{2}{p'}}) \leq C_2 \left(\frac{r}{r_1}\right)^\alpha \quad (20)$$

where $C_1 = C_1(|\Omega|, \|f\|_p, p, \gamma)$, $C_2 := C_1 + C$ (we used the inequality $r_1 \leq 1$ in the latter estimate). Since the same holds true also for $u_{\Sigma'}$, we get

$$\int_{B_r(x_0)} |\nabla u_{\Sigma'}|^2 dx \leq C_2 \left(\frac{r}{r_1}\right)^\alpha. \quad (21)$$

Applying to (17) and (18) the estimates of Lemma 3.6 for u_Σ and $u_{\Sigma'}$ respectively (combined with (20) and (21) respectively), we arrive at (16), concluding the proof. \square

4 First qualitative properties

In this section, we prove some topological and geometrical properties of the minimizers for Problem 1.1.

4.1 Absence of loops

The following result holds true.

Theorem 4.1. *Let $f \in L^p(\Omega)$, $p > 2$. Then every solution Σ of the penalized Problem 1.1 contains no closed curves (homeomorphic images of S^1), hence $\mathbb{R}^2 \setminus \Sigma$ is connected.*

The idea of the proof of this result is to see that if Σ has a loop, then we can cut a small piece of this loop and remain connected; this cut decreases the length and increases the energy. If we choose this cut properly, namely where the curve is “flat”, then the energy estimate from Section 3.3 shows that these two variations are not of the same order, which leads to a contradiction, see the proof below. Before this proof, we provide the following geometric lemma asserting that such a cut can be done.

Lemma 4.2. *Let Σ be a closed connected set in \mathbb{R}^2 , containing a simple closed curve Γ (a homeomorphic image of S^1) and such that $\mathcal{H}^1(\Sigma) < \infty$. Then \mathcal{H}^1 -a.e. point $x \in \Gamma$ is such that*

- “noncut”: there is a sequence of (relatively) open sets $D_n \subset \Sigma$ satisfying
 - (i) $x \in D_n$ for all sufficiently large n ;
 - (ii) $\Sigma \setminus D_n$ are connected for all n ;
 - (iii) $\text{diam } D_n \searrow 0$ as $n \rightarrow \infty$;
 - (iv) D_n are connected for all n .
- “flatness”: there exists a “tangent” line P to Σ at x in the sense that $x \in P$ and

$$\lim_{r \rightarrow 0^+} \beta_{\Sigma, P}(x, r) = 0 \quad \text{where } \beta_{\Sigma, P}(x, r) := \sup_{y \in \Sigma \cap B_r(x)} \frac{\text{dist}(y, P)}{r}.$$

Proof. First, we apply [29, Lemma 5.6], stating that under the hypotheses on Σ , \mathcal{H}^1 -a.e. point $x \in \Gamma$ is a noncut point for Σ (i.e. a point such that $\Sigma \setminus \{x\}$ is connected). Then [9, Lemma 6.1] affirms that for every noncut point there are connected neighborhoods that can be cut leaving the set connected, i.e. (i)-(iv) are satisfied for a suitable sequence D_n . The second requirement relies on the standard fact that closed connected sets with finite length are rectifiable (see, e.g., [27, Proposition 3.4] or [4, Proposition 2.2]). \square

Proof of Theorem 4.1. Assume by contradiction that for some $\lambda > 0$ a minimizer Σ of \mathcal{F}_λ over closed connected subsets of $\bar{\Omega}$ contains a closed curve $\Gamma \subset \Sigma$. From Lemma 4.2, we have that there exists a point $x \in \Gamma$ which is a noncut point and such that Σ is differentiable at x . Therefore there exist sets $D_n \subset \Sigma$ and a straight line P as in Lemma 4.2. We denote $r_n := \text{diam } D_n$ so that $D_n \subset \Sigma \cap B_{r_n}(x)$. The flatness of Σ at x implies that for some given $\varepsilon > 0$, there exists an $r^* > 0$ such that

$$\arcsin \beta_{\Sigma, P}(x, r) \leq \varepsilon\pi/2 \quad \text{for all } r \in (0, r^*].$$

Thus every connected $S \subset \partial B_r(x) \setminus \Sigma$ satisfies

$$\mathcal{H}^1(S) \leq (\pi + 2 \arcsin \beta_{\Sigma, P}(x, r))r = (1 + \varepsilon)\pi r, \quad r \in (0, r^*],$$

and hence using Proposition 3.7 with $\gamma := (1 + \varepsilon)\pi$ and $\Sigma' = \Sigma \setminus D_n$ when $r_n \leq R$, we get

$$|E(u_{\Sigma \setminus D_n}) - E(u_\Sigma)| \leq Cr_n^{\frac{2\pi}{\gamma}}.$$

But since

$$\mathcal{H}^1(\Sigma \setminus D_n) = \mathcal{H}^1(\Sigma) - \mathcal{H}^1(D_n) \leq \mathcal{H}^1(\Sigma) - r_n,$$

we get

$$\mathcal{F}_\lambda(\Sigma \setminus D_n) \leq \mathcal{F}_\lambda(\Sigma) - \lambda r_n + Cr_n^{\frac{2\pi}{\gamma}}.$$

Recalling that $2/p' > 1$ and choosing $\varepsilon < 1/2$ (of course, this affects the value of C and of r^*), one has

$$\mathcal{F}_\lambda(\Sigma \setminus D_n) \leq \mathcal{F}_\lambda(\Sigma) - \lambda r_n + o(r_n)$$

as $r_n \rightarrow 0^+$, which for sufficiently small r_n contradicts the minimality of Σ , hence proving that Σ does not contain closed curves. To prove the last assertion in Theorem 4.1, we use theorem II.5 of [19, § 61], stating that if $D \subset \mathbb{R}^2$ is a bounded connected set with locally connected boundary, then there is a simple closed curve $S \subset \partial D$. Thus, if $\mathbb{R}^2 \setminus \Sigma$ were disconnected, there would exist a bounded connected component D of $\mathbb{R}^2 \setminus \Sigma$ such that $\partial D \subset \Sigma$, and hence Σ would contain a simple closed curve, contrary to what has been already proven. \square

4.2 Ahlfors regularity

It is not difficult to show that the minimizers of Problem 1.1 are Ahlfors regular under quite nonrestrictive conditions on the data. Recall that a set $\Sigma \subset \mathbb{R}^2$ is called Ahlfors regular, if there exist some constants $c > 0$, $r_0 > 0$ and $C > 0$ such that for every $r \in (0, r_0)$ and for every $x \in \Sigma$ one has

$$cr \leq \mathcal{H}^1(\Sigma \cap B_r(x)) \leq Cr, \quad (22)$$

a singleton being considered Ahlfors regular by definition. The constants C and c will be further referred to as *upper and lower Ahlfors regularity constants* of Σ respectively. It is known that Ahlfors regularity of a closed connected set Σ implies *uniform rectifiability* (a kind of “quantitative rectifiability” which is somewhat stronger than the classical rectifiability used in geometric measure theory) of Σ , which provides several nice analytical properties of Σ , see for example [13], and will be used later several times.

If Σ is closed and connected, then the lower estimate in (22) is trivial: in fact, for all $r < \text{diam } \Sigma/2$ one has $\Sigma \cap \partial B_r(x) \neq \emptyset$, and hence

$$\mathcal{H}^1(\Sigma \cap B_r(x)) \geq r,$$

when $x \in \Sigma$. Hence, for such Σ the proof of Ahlfors regularity reduces to verifying that for every $x \in \Sigma$ and for all $r \in (0, r_0)$ with some $r_0 > 0$ independent of x one has

$$\frac{\mathcal{H}^1(\Sigma \cap B_r(x))}{r} \leq C. \quad (23)$$

Theorem 4.3. *Let $f \in L^p(\Omega)$, $p > 2$. Then every solution Σ of Problem 1.1 is Ahlfors regular.*

Remark 4.4. Looking closer at the proof of the above Theorem 4.3, we observe that the upper Ahlfors regularity constant may possibly depend only on $|\Omega|$, $\|f\|_p$ and p .

Proof. We show that for every $\lambda > 0$, every minimizer Σ of \mathcal{F}_λ among closed connected subsets of $\bar{\Omega}$ satisfies (23) with some $C > 2\pi$ and $r_0 \in (0, \text{diam } \Sigma/4)$.

Let $x \in \Sigma$ be arbitrary and set $R := \text{diam } \Sigma/4$, so that $\partial B_{2r}(x) \cap \Sigma \neq \emptyset$ for all $r \in (0, R]$. For every $r \in (0, R]$ we set $\Sigma_r := (\Sigma \setminus B_r(x)) \cup (\partial B_r(x) \cap \bar{\Omega})$. Clearly, $\Sigma_r \subset \bar{\Omega}$ is still closed, connected and

$$\mathcal{H}^1(\Sigma_r) \leq \mathcal{H}^1(\Sigma) - \mathcal{H}^1(\Sigma \cap B_r(x)) + 2\pi r. \quad (24)$$

Using Proposition 3.7 with $\gamma = 2\pi$ and Σ_r instead of Σ' , we get

$$|E(u_{\Sigma_r}) - E(u_\Sigma)| \leq Cr.$$

for all $r \in (0, r_0]$ for $r_0 = \min\{R, 1\}$ and $C > 0$ independent on $x \in \Sigma$. But in view of (24) we get

$$\mathcal{F}_\lambda(\Sigma_r) \leq \mathcal{F}_\lambda(\Sigma) - \lambda \mathcal{H}^1(\Sigma \cap B_r(x)) + 2\pi\lambda r + Cr.$$

Therefore the optimality of Σ implies

$$-\lambda \mathcal{H}^1(\Sigma \cap B_r(x)) + 2\pi\lambda r + Cr \geq 0, \quad (25)$$

for all $r \in (0, r_0]$. Clearly, then (25) gives (23) and hence Ahlfors regularity of Σ . \square

5 Flatness and small energy implies C^1 regularity

In this section we find sufficient conditions for Σ in a ball $B_r(x)$ which imply that $\Sigma \cap B_{r/2}(x)$ is a nice C^1 curve. The strategy vaguely follows the approach of David in [11] where a similar work is done for Mumford-Shah minimizers, but adapted to our problem which is a Dirichlet problem of min-max type rather than a Neumann problem of min-min type in [11]. The connectedness constraint makes also a big difference with the Mumford-Shah problem. The general tools are a decay of energy provided that Σ stays “flat” thanks to the monotonicity formula, and on the other hand, a control on the flatness when the energy is small. We then conclude by bootstrapping both estimates.

From this section on, we will always assume $\lambda = 1$ for simplicity. Of course this is not restrictive regarding the regularity theory.

5.1 Control of the energy when Σ is flat

For any $x \in \Omega$ and $r > 0$ such that $B_r(x) \subset \Omega$ we denote by $\beta_\Sigma(x, r)$ the flatness of Σ in $B_r(x)$ defined through

$$\beta_\Sigma(x, r) := \inf_{P \ni x} \frac{1}{r} d_H(\Sigma \cap B_r(x), P \cap B_r(x)),$$

where d_H is the Hausdorff distance and where the infimum is taken over all affine lines P passing through x . Notice that the inf above is attained, i.e. is actually a minimum.

We will also need a variant where the proximity to affine lines is checked only in an annulus and not in the whole ball. Precisely, for $0 < s < r$ we denote

$$\beta_\Sigma(x, r, s) := \inf_{P \ni x} \frac{1}{r} d_H(\Sigma \cap B_r(x) \setminus B_s(x), P \cap B_r(x) \setminus B_s(x)),$$

where again the inf is taken over all affine lines P passing through x .

Observe that for all $0 < s < r$, it directly comes from the definition that

$$\beta_\Sigma(x, r, s) \leq \beta_\Sigma(x, r),$$

and the main point about $\beta_\Sigma(x, r, s)$ is the following obvious fact:

$$\beta_\Sigma(x, r) \leq \varepsilon \text{ and } \Sigma \Delta \Sigma' \subset B_s(x) \text{ imply } \beta_{\Sigma'}(x, r, s) \leq \varepsilon.$$

Observe also that for all $a \in (0, 1)$ we have

$$\beta_\Sigma(x, ar) \leq \frac{1}{a} \beta_\Sigma(x, r). \tag{26}$$

Our first aim is to use the monotonicity formula to control the energy of u_Σ around points where β_Σ is small: this is done in Proposition 5.5 below. For this purpose we seek for a lemma similar to Lemma 3.3, but where the assumption (6) is replaced by an assumption on $\beta_\Sigma(x, r)$ only. This leads to new difficulties, because even if Σ is connected and flat around a point $x \in \Sigma$, it may happen that $\Sigma \cap B_r(x)$ is not connected (see Figure 5.1). We state the lemma when $\gamma = \pi + \pi/3$ (so that $2\pi/\gamma = 3/2$); we could have chosen any $\gamma = \pi + \varepsilon$ with ε small (leading to $2\pi/\gamma$ as close as 2 as required), though this specific choice of γ is sufficient for our purpose, since our main goal is to allow an exponent strictly bigger than 1. Moreover, it is more convenient to work on harmonic functions, and then compare u_Σ with its harmonic replacement to obtain a similar statement for u_Σ . Therefore the following lemmas are stated first in this more convenient framework of harmonic functions.

We call then *Dirichlet minimizer* $u \in g + H_0^1(D \setminus \Sigma)$ any function that minimizes the Dirichlet energy $w \mapsto \int_D |\nabla w|^2 dx$ over $g + H_0^1(D \setminus \Sigma)$.

Lemma 5.1. *Let $\Sigma \subset \overline{\Omega}$ be a closed and connected set, $g \in H_0^1(\Omega \setminus \Sigma)$, $x_0 \in \Sigma$, $2r_1\varepsilon < r_0 < r_1 < \text{diam}(\Sigma)/2$ and*

$$\beta_\Sigma(x_0, r_1, r_0) \leq \varepsilon \quad (27)$$

for some $0 < \varepsilon \leq 1/2$. Then for every Dirichlet minimizer $u \in g + H_0^1(B_{r_1}(x_0) \setminus \Sigma)$ and for every $r \in [r_0, r_1]$ one has

$$\int_{B_r} |\nabla u|^2 dx \leq 4 \left(\frac{r}{r_1} \right)^{\frac{3}{2}} \int_{B_{r_1}} |\nabla u|^2 dx.$$

To get a proof of this result, we need first the following two lemmas: the first one is a version of Lemma 3.3 for harmonic functions, the second one is a purely geometric statement.

Lemma 5.2. *Let $\Sigma \subset \overline{\Omega}$ be a closed set, $g \in H_0^1(\Omega \setminus \Sigma)$, $x_0 \in \overline{\Omega}$. Assume that (6) is valid and $\gamma \in [\gamma_\Sigma(x_0, r_0, r_1), 2\pi] \setminus \{0\}$ (see (5) for a definition of γ_Σ). Then for every Dirichlet minimizer $u \in g + H_0^1(B_{r_1}(x_0) \setminus \Sigma)$ one has that the function*

$$r \in [r_0, r_1] \mapsto r^{-\frac{2\pi}{\gamma}} \int_{B_r(x_0)} |\nabla u|^2 dx,$$

is nondecreasing.

The proof of this lemma is exactly the same as the one of Lemma 3.3 (with $f = 0$) so we omit it.

As we said before, to replace the assumption (6) by another one relying only on the flatness $\beta_\Sigma(x_0, r_1, r_0)$, we face the difficulty that it may happen, even if Σ is connected, that $\partial B_r(x_0) \cap \Sigma = \emptyset$ for some $r \in (r_0, r_1)$. To handle this difficulty, we establish the following geometric fact.

Lemma 5.3. *Let $\Sigma \subset \mathbb{R}^2$ be a closed and arcwise connected set. Assume that $x_0 \in \Sigma$ and $r_1\varepsilon < r_0 < r_1 < \text{diam}(\Sigma)/2$ are such that*

$$\beta_\Sigma(x_0, r_1, r_0) \leq \varepsilon \quad (28)$$

for some $0 < \varepsilon < 1$. Let $A \subset [r_0, r_1]$ be the set of all r for which

$$\sup \left\{ \frac{\mathcal{H}^1(S)}{r} : S \text{ connected component of } \partial B_r(x_0) \setminus \Sigma \right\} > \pi + 2 \arcsin \left(\frac{\varepsilon r_1}{r} \right).$$

Then A is an open interval of length less than εr_1 (possibly empty).

Remark 5.4. Let us recall that any compact and connected set $\Sigma \subset \mathbb{R}^2$ satisfying $\mathcal{H}^1(\Sigma) < +\infty$ is automatically arcwise connected (see for instance [11, Corollary 30.2, p. 186]).

Proof. In this proof, every ball is centered at x_0 . Let P be the line that realizes the infimum in the definition of $\beta_\Sigma(x_0, r_1, r_0)$. To simplify the description of the construction, we assume the cartesian coordinate system to be chosen so as to have x_0 as the origin and P coinciding with the x_1 axis, so that $P \cap B_{r_1}$ is identified with the segment $[-r_1, r_1]$ along this axis (see Figure 5.1). This gives the notion of “right” (belonging to positive half-plane $\Pi^+ := \{x \in \mathbb{R}^2 : x_1 > 0\}$) and “left” (belonging to the negative half-plane $\Pi^- := \mathbb{R}^2 \setminus \Pi^+$). We say that an $x \in \Sigma \cap \partial B_r$, with $r \in [r_0, r_1]$, is *right* (resp. *left*) connected to $\Sigma \setminus B_{r_1}$, if it is connected to some point of $\Sigma \setminus B_{r_1}$ via an arc in Σ , escaping the ball B_{r_1} on the right (resp. on the left). Note that every such point must be either right or left connected (or both) to $\Sigma \setminus B_{r_1}$, because $\Sigma \cap B_{r_1} \setminus B_{r_0}$ belongs to an εr_1 -strip around P which does not contain the whole B_{r_1} (since $\varepsilon < 1$).

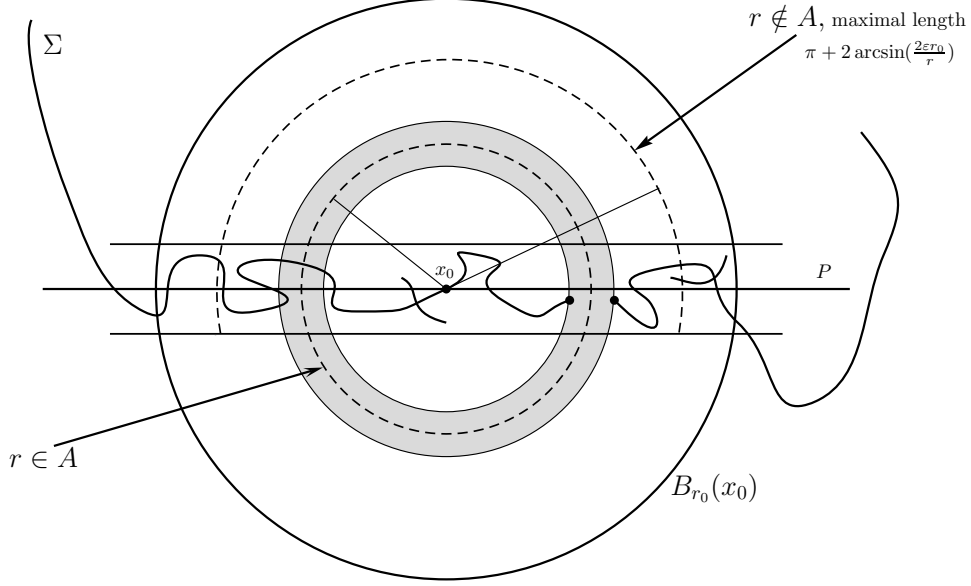

Figure 5.1: Situation in the proof of Lemma 5.3: $\beta_\Sigma(x_0, r_0, r_1) \leq \varepsilon$

Define now two (possibly empty) open intervals I_+ and I_- in the following way. If there is a point in $\Sigma \cap B_{r_1} \cap \Pi^+ \setminus B_{r_0}$ right but not left connected to $\Sigma \setminus B_{r_1}$ (otherwise set $I_+ := \emptyset$), then we let $I_+ := (t_+^-, t_+^+)$, where

$$\begin{aligned} t_+^- &:= \sup\{r \in [r_0, r_1]: \text{there is an } x \in \Sigma \cap B_r \cap \Pi^+ \text{ left connected to } \Sigma \setminus B_{r_1}\}, \\ t_+^+ &:= \inf\{r \in [r_0, r_1]: \text{there is an } x \in \Sigma \cap B_r \cap \Pi^+ \text{ right connected to } \Sigma \setminus B_{r_1}\}, \end{aligned}$$

where $t_+^- := r_0$ by definition, if $\Sigma \cap B_{r_1} \cap \Pi^+ \setminus B_{r_0}$ contains no point left connected to $\Sigma \setminus B_{r_1}$. We prove a couple of claims regarding this construction.

CLAIM A. One has for every $r \in (t_+^-, r_1]$ that $\Sigma \cap \partial B_r \cap \Pi^+ \neq \emptyset$, because $\varepsilon r_1 < r_0$ implies that an arc of Σ containing a point in $\Sigma \cap \partial B_t \cap \Pi^+$, $t \in [r_0, r_1]$, and escaping from B_{r_1} on the right intersects all ∂B_r for $r \in [t, r_1]$. Analogously, for every $r \in [r_0, t_+^-)$ one has $\Sigma \cap \partial B_r \cap \Pi^+ \neq \emptyset$. Moreover, this reasoning shows that $t_+^- < t_+^+$.

CLAIM B. Observe that sup and inf in the above definitions are attained. In fact, letting $x_k^\pm \in \Sigma \cap B_{r_k^\pm} \cap \Pi^+$ with $\lim_k r_k^\pm = t_r^\pm$ and x_k^- left-connected (resp. x_k^+ right-connected) to $\Sigma \setminus B_{r_1}$, we have that up to a subsequence of k (not relabeled) $x_k^\pm \rightarrow x^\pm \in \Sigma \cap B_{t_r^\pm} \cap \Pi^+$, and both points x^\pm have to be right or left connected to $\Sigma \setminus B_{r_1}$. But $t_+^+ > t_+^-$ implies then that x^- is left-connected (resp. x^+ is right-connected) to $\Sigma \setminus B_{r_1}$, proving the claim.

Combining Claim B with Claim A we have that $\Sigma \cap \partial B_r \cap \Pi^+ \neq \emptyset$ for every $r \in [r_0, r_1] \setminus I_+$.

We define now symmetrically the interval I_- . If there is a point in $\Sigma \cap B_{r_1} \cap \Pi^- \setminus B_{r_0}$ left but not right connected to $\Sigma \setminus B_{r_1}$ (otherwise set $I_- := \emptyset$), then we let $I_- := (t_-^-, t_-^+)$, where

$$\begin{aligned} t_-^- &:= \sup\{r \in [r_0, r_1]: \text{there is an } x \in \Sigma \cap B_r \cap \Pi^- \text{ right connected to } \Sigma \setminus B_{r_1}\}, \\ t_-^+ &:= \inf\{r \in [r_0, r_1]: \text{there is an } x \in \Sigma \cap B_r \cap \Pi^- \text{ left connected to } \Sigma \setminus B_{r_1}\}, \end{aligned}$$

where $t_-^- := r_0$ by definition, if $\Sigma \cap B_{r_1} \cap \Pi^- \setminus B_{r_0}$ contains no point right connected to $\Sigma \setminus B_{r_1}$. With an absolutely symmetric argument we have that $\Sigma \cap \partial B_r \cap \Pi^- \neq \emptyset$ for every $r \in [r_0, r_1] \setminus I_-$.

Clearly, every circumference ∂B_t for $t \in [r_0, r_1] \setminus (I_+ \cup I_-)$ necessarily meets a point of Σ in the εr_1 -strip around P both in Π^+ and in Π^- , and thus

$$\sup \left\{ \frac{\mathcal{H}^1(S)}{t} : S \text{ connected component of } \partial B_t \setminus \Sigma \right\} \leq \pi + 2 \arcsin \left(\frac{\varepsilon r_1}{t} \right).$$

On the other hand, if I_+ (resp. I_-) is nonempty, then its length cannot exceed εr_1 , because by (28) for each point $x \in P \cap B_{r_1} \setminus B_{r_0}$ there is an $y \in \Sigma \cap B_{r_1} \setminus B_{r_0}$ which is at most εr_1 distant from x . Further, both I_+ and I_- may not be simultaneously nonempty, since otherwise Σ would be disconnected ($x_0 \in \Sigma$ could not be connected by an arc to a point of $\Sigma \setminus B_{r_1}$). We deduce that $A = I_+ \cup I_-$ is an open interval of length not exceeding εr_1 . \square

Now we are in a position to prove Lemma 5.1.

Proof of Lemma 5.1. In this proof, every ball is centered at x_0 . Observe first that the function $r \in [2\varepsilon r_1, r_1] \mapsto \pi + 2 \arcsin\left(\frac{\varepsilon r_1}{r}\right)$ is decreasing, and is therefore always smaller than $\pi + \frac{\pi}{3}$, achieved at $r = 2\varepsilon r_1$. Let $A := (t_1, t_2)$ be the set of bad radii given by Lemma 5.3. When $r \in [t_2, r_1]$, we apply Lemma 5.2 with $\gamma = \pi + \frac{\pi}{3}$ thus obtaining directly

$$\int_{B_r} |\nabla u|^2 dx \leq \left(\frac{r}{r_1}\right)^{\frac{3}{2}} \int_{B_{r_1}} |\nabla u|^2 dx. \quad (29)$$

If $r \in (t_1, t_2)$. Then since (29) holds for t_2 we can simply write

$$\begin{aligned} \int_{B_r} |\nabla u|^2 dx &\leq \int_{B_{t_2}} |\nabla u|^2 dx \leq \left(\frac{t_2}{r_1}\right)^{1+\frac{1}{2}} \int_{B_{r_1}} |\nabla u|^2 dx \quad \text{by Lemma 5.2} \\ &\leq \left(\frac{r + \varepsilon r_1}{r_1}\right)^{\frac{3}{2}} \int_{B_{r_1}} |\nabla u|^2 dx \quad \text{by Lemma 5.3} \\ &\leq \left(\frac{2r}{r_1}\right)^{\frac{3}{2}} \int_{B_{r_1}} |\nabla u|^2 dx \\ &\leq 4 \left(\frac{r}{r_1}\right)^{\frac{3}{2}} \int_{B_{r_1}} |\nabla u|^2 dx. \end{aligned}$$

Finally, if $r \in [r_0, t_1]$, we apply Lemma 5.2 on $[r_0, t_1]$ which yields

$$\int_{B_r} |\nabla u|^2 dx \leq \left(\frac{r}{t_1}\right)^{\frac{3}{2}} \int_{B_{t_1}} |\nabla u|^2 dx \leq \left(\frac{r}{t_1}\right)^{\frac{3}{2}} \int_{B_{t_2}} |\nabla u|^2 dx.$$

Combining this estimate with (29) applied with $r := t_2$, we get

$$\int_{B_r} |\nabla u|^2 dx \leq \left(\frac{r}{t_1}\right)^{\frac{3}{2}} \left(\frac{t_2}{r_1}\right)^{\frac{3}{2}} \int_{B_{r_1}} |\nabla u|^2 dx \leq 4 \left(\frac{r}{r_1}\right)^{\frac{3}{2}} \int_{B_{r_1}} |\nabla u|^2 dx,$$

because

$$t_2/t_1 \leq (t_1 + \varepsilon r_1)/t_1 = 1 + \varepsilon r_1/t_1 \leq 1 + \varepsilon r_1/2\varepsilon r_1 \leq 2,$$

concluding the proof. \square

We are now ready to state a useful decay result on u_Σ .

Proposition 5.5. *Let $\Omega \subset \mathbb{R}^2$, $f \in L^p(\Omega)$ with $p > 2$, $\Sigma \subset \bar{\Omega}$ be a closed connected set, $x_0 \in \Sigma$. Suppose $2r_1\varepsilon < r_0 < r_1 < \text{diam}(\Sigma)/2$ and*

$$\beta_\Sigma(x_0, r_1, r_0) \leq \varepsilon \quad (30)$$

for some $\varepsilon \in (0, 1/2]$. Then for every $r \in [r_0, r_1]$ one has that

$$\int_{B_r(x_0)} |\nabla u_\Sigma|^2 dx \leq 8 \left(\frac{r}{r_1}\right)^{\frac{3}{2}} \int_{B_{r_1}(x_0)} |\nabla u_\Sigma|^2 dx + Cr_1^{\frac{2}{p}} \quad (31)$$

for some constant $C = C(|\Omega|, p, \|f\|_p) > 0$.

Proof. In this proof, every ball is centered at x_0 . Let w be the harmonic replacement of u_Σ in B_{r_1} , i.e. w is a Dirichlet minimizer in B_{r_1} : it is harmonic in $B_{r_1} \setminus \Sigma$ with Dirichlet condition $w = 0$ on $\Sigma \cap B_{r_1}$ and $w = u_\Sigma$ on $\partial B_{r_1} \setminus \Sigma$. This function is found by minimizing the Dirichlet energy $\int_{B_{r_1}} |\nabla w|^2 dx$ among all w satisfying $w - u_\Sigma \in H_0^1(B_{r_1} \setminus \Sigma)$. Then Lemma 5.1 applies to w giving

$$\int_{B_r} |\nabla w|^2 dx \leq 4 \left(\frac{r}{r_1} \right)^{\frac{3}{2}} \int_{B_{r_1}} |\nabla w|^2 dx \leq 4 \left(\frac{r}{r_1} \right)^{\frac{3}{2}} \int_{B_{r_1}} |\nabla u_\Sigma|^2 dx. \quad (32)$$

The last inequality comes from the fact that w minimizes the energy in B_{r_1} and u_Σ is a competitor. Now u_Σ minimizes E so that, extending w by u_Σ outside B_{r_1} we can write

$$\int_{\Omega} |\nabla u_\Sigma|^2 dx - 2 \int_{\Omega} u_\Sigma f dx = 2E(u_\Sigma) \leq 2E(w) = \int_{\Omega} |\nabla w|^2 dx - 2 \int_{\Omega} w_\Sigma f dx,$$

that is,

$$\int_{B_{r_1}} |\nabla u_\Sigma|^2 dx - \int_{B_{r_1}} |\nabla w|^2 dx \leq 2 \int_{B_{r_1}} (u_\Sigma - w) f dx \leq Cr_1^{\frac{2}{p}} \quad (33)$$

for some $C = C(|\Omega|, \|f\|_p, p) > 0$, where in the last estimate we used the Hölder inequality together with the fact that u_Σ and hence w are bounded (Proposition 2.1). On the other hand, for any $r \in [r_0, r_1]$, we have

$$\begin{aligned} \int_{B_r} |\nabla u_\Sigma|^2 dx &\leq 2 \int_{B_r} |\nabla w|^2 dx + 2 \int_{B_r} |\nabla(w - u_\Sigma)|^2 dx \\ &\leq 2 \int_{B_r} |\nabla w|^2 dx + 2 \int_{B_{r_1}} |\nabla(w - u_\Sigma)|^2 dx \\ &= 2 \int_{B_r} |\nabla w|^2 dx + 2 \int_{B_{r_1}} |\nabla u_\Sigma|^2 dx - 2 \int_{B_{r_1}} |\nabla w|^2 dx \end{aligned} \quad (34)$$

because ∇w and $\nabla(u_\Sigma - w)$ are orthogonal in $L^2(B_{r_1} \setminus \Sigma)$. Combining (32), (33) and (34) we arrive at (31) thus concluding the proof. \square

Let us now recall the following notation. For any $\Sigma \in \mathcal{K}(\Omega)$ we denote by

$$\omega_\Sigma(x, r) = \max_{\Sigma' \in \mathcal{K}(\Omega); \Sigma' \Delta \Sigma \subset \overline{B}_r(x)} \left(\frac{1}{r} \int_{B_r(x)} |\nabla u_{\Sigma'}|^2 dx \right). \quad (35)$$

Remark 5.6. The maximum in (35) is attained. Indeed, if Σ_k is a maximizing sequence, then up to a subsequence $\Sigma_k \rightarrow \Sigma_0$ in the Hausdorff distance and clearly $\Sigma_0 \Delta \Sigma \subset \overline{B}_r(x)$. But then Šverák Theorem 2.3 says that $\nabla u_{\Sigma_k} \rightarrow \nabla u_{\Sigma_0}$ strongly in $L^2(\Omega)$, and therefore Σ_0 is a maximizer for (35).

Notice that we also have, for $a \in (0, 1)$, that

$$\omega_\Sigma(x, ar) \leq \frac{1}{a} \omega_\Sigma(x, r). \quad (36)$$

The next proposition states that $\omega_\Sigma(x, \cdot)$ decays at smaller scales, provided that $\beta_\Sigma(x, \cdot)$ is small.

Proposition 5.7. *Let $\Omega \subset \mathbb{R}^2$, $f \in L^p(\Omega)$ with $p > 2$, $\Sigma \subset \overline{\Omega}$ be a closed connected set, $x_0 \in \Sigma$ and assume*

$$\beta_\Sigma(x_0, r_1) \leq \varepsilon$$

for some $0 < \varepsilon < 1/2$ and $r_1 < \text{diam}(\Sigma)/2$. Then for any $r \in (2\varepsilon r_1, r_1)$ we have

$$\omega_\Sigma(x_0, r) \leq 8 \left(\frac{r}{r_1} \right)^{\frac{1}{2}} \omega_\Sigma(x_0, r_1) + Cr_1^{\frac{2}{p}} \frac{1}{r}$$

for some constant $C = C(|\Omega|, p, \|f\|_p) > 0$.

Proof. Every ball in this proof is centered at x_0 . Let Σ' be the maximizer for (35). Since $\Sigma \Delta \Sigma' \subset B_r$ we have that

$$\beta_{\Sigma'}(x_0, r_1, r) \leq \varepsilon$$

and therefore Proposition 5.5 (applied with $r_0 := r$) gives for every $r \in (2\varepsilon r_1, r_1)$ the estimate

$$\begin{aligned} \omega_\Sigma(x_0, r) &= \frac{1}{r} \int_{B_r} |\nabla u_{\Sigma'}|^2 dx \leq 8 \left(\frac{r}{r_1} \right)^{\frac{1}{2}} \frac{1}{r_1} \int_{B_{r_1}} |\nabla u_{\Sigma'}|^2 dx + Cr_1^{\frac{2}{p}} \frac{1}{r} \\ &\leq 8 \left(\frac{r}{r_1} \right)^{\frac{1}{2}} \omega_\Sigma(x_0, r_1) + Cr_1^{\frac{2}{p}} \frac{1}{r}, \end{aligned} \quad (37)$$

showing the claim. \square

We now state a first estimate on defect of minimality.

Proposition 5.8. *Let $\Omega \subset \mathbb{R}^2$, $f \in L^p(\Omega)$ with $p > 2$, $\Sigma \subset \bar{\Omega}$ be a closed connected set, and assume that $x_0 \in \Sigma$, and*

$$\beta_\Sigma(x_0, r_1) \leq \varepsilon$$

for some $0 < \varepsilon < 1/4$ and $r_1 < \text{diam}(\Sigma)/2$. Then for any $r \in (2\varepsilon r_1, r_1/2]$ and for any closed and connected set $\Sigma' \subset \bar{\Omega}$ satisfying $\Sigma \Delta \Sigma' \subset B_r(x_0)$ the estimate

$$E(u_\Sigma) - E(u_{\Sigma'}) \leq Cr \left(\frac{r}{r_1} \right)^{\frac{1}{2}} \omega_\Sigma(x_0, r_1) + Cr_1^{\frac{2}{p}} \quad (38)$$

holds with a constant $C = C(|\Omega|, p, \|f\|_p) > 0$.

Proof. Every ball in this proof is centered at x_0 . Take an arbitrary $\varphi \in \text{Lip}(\mathbb{R}^2)$ as in the statement of Lemma 3.6, i.e. such that $\|\varphi\|_\infty \leq 1$, $\varphi = 1$ over B_{2r}^c , $\varphi = 0$ over B_r and $\|\nabla \varphi\|_\infty \leq 1/r$. From Lemma 3.1 we have

$$\begin{aligned} E(u_\Sigma) - E(u_{\Sigma'}) &\leq \int_{B_{2r}} u_{\Sigma'} f (1 - \varphi) dx + \int_{B_{2r}} u_{\Sigma'}^2 |\nabla \varphi|^2 dx \\ &\quad + \int_{B_{2r}} u_{\Sigma'} \varphi \nabla u_{\Sigma'} \cdot \nabla \varphi dx. \end{aligned}$$

We obtain then the following chain of estimates (with the constant C changing from line to line)

$$\begin{aligned} E(u_\Sigma) - E(u_{\Sigma'}) &\leq C \int_{B_{2r}} |\nabla u_{\Sigma'}|^2 dx + Cr^{\frac{2}{p}} \quad \text{by Lemma 3.6} \\ &\leq Cr \omega_\Sigma(x_0, 2r) + Cr^{\frac{2}{p}} \quad \text{by definition of } \omega_\Sigma \\ &\leq Cr \left(\frac{r}{r_1} \right)^{\frac{1}{2}} \omega_\Sigma(x_0, r_1) + Cr_1^{\frac{2}{p}} + Cr^{\frac{2}{p}} \quad \text{by Proposition 5.7} \\ &\leq Cr \left(\frac{r}{r_1} \right)^{\frac{1}{2}} \omega_\Sigma(x_0, r_1) + Cr_1^{\frac{2}{p}} \quad \text{because } r \leq r_1, \end{aligned}$$

concluding the proof. \square

It is worth observing (though we will not use it in the sequel) that monotonicity holds also for ω_Σ , as the following statement asserts.

Corollary 5.9. *Let $\Sigma \subset \bar{\Omega}$ be a connected and closed set, $f \in L^p(\Omega)$, where $p > 2$, and $x_0 \in \Sigma$. Then*

$$r \mapsto \omega_\Sigma(x_0, r) + Cr^{\frac{2}{p'}-1},$$

is nondecreasing on $(0, \text{diam}(\Sigma)/2)$, where $C = C(|\Omega|, p, \|f\|_p) > 0$.

Proof. Balls in this proof are centered at x_0 . Let $0 < r_0 < r_1 < \text{diam}(\Sigma)/2$. Since Σ is connected, (6) is satisfied for $r \in (0, r_1]$. Let Σ' be a maximizer in (35) for $\omega_\Sigma(x_0, r_0)$; then Σ' satisfies (6) for $r \in [r_0, r_1]$. Applying Remark 3.4 to $u_{\Sigma'}$, we get

$$\begin{aligned} \omega_\Sigma(x_0, r_0) + Cr_0^{\frac{2}{p'}-1} &= \frac{1}{r_0} \int_{B_{r_0}} |\nabla u_{\Sigma'}|^2 dx + Cr_0^{\frac{2}{p'}-1} \\ &\leq \frac{1}{r_1} \int_{B_{r_1}} |\nabla u_{\Sigma'}|^2 dx + Cr_1^{\frac{2}{p'}-1} \\ &\leq \omega_\Sigma(x_0, r_1) + Cr_1^{\frac{2}{p'}-1}, \end{aligned}$$

showing the claim. \square

5.2 Density estimates

We now establish our main results about the density of the minimizer Σ at the point $x_0 \in \Sigma$. The first claim is weak in the sense that β appears in the error terms in the density estimate, but will be used to find some good radius s for which $\#\Sigma \cap \partial B_s(x_0) = 2$, as stated in the second claim. The third claim provides a density estimate similar to the one given by the first claim, but without paying β in the error terms, provided that $\#\Sigma \cap \partial B_s(x_0) = 2$; this will be our main estimate that leads to regularity.

Proposition 5.10. *Let $\Omega \subset \mathbb{R}^2$ be a C^1 domain, $f \in L^p(\Omega)$ with $p > 2$, $\Sigma \subset \bar{\Omega}$ be a minimizer for Problem 1.1, $C_0 > 0$ its upper Ahlfors regularity constant. Then there exists an $r_\Omega > 0$ (depending on Ω) such that for $x_0 \in \Sigma$ and $0 < r_1 < \min(r_\Omega, \text{diam}(\Sigma)/2)$ the following assertions hold.*

(i) If

$$\beta_\Sigma(x_0, 2r_1) \leq \frac{10^{-5}}{20 + 4C_0}, \quad (39)$$

then for any $r \in [r_1/2, r_1]$,

$$\mathcal{H}^1(\Sigma \cap B_r(x_0)) \leq 2r + (20 + 4C_0)r\beta_\Sigma(x_0, 2r) + Cr \left(\frac{r}{r_1}\right)^{\frac{1}{2}} \omega_\Sigma(x_0, r_1) + Cr_1^{\frac{2}{p'}} \quad (40)$$

with the constant $C = C(|\Omega|, p, \|f\|_p) > 0$ such that the estimate (38) from Proposition 5.8 holds.

(ii) If in addition to (39) the estimate

$$\omega_\Sigma(x_0, r_1) + r_1^{\frac{2}{p'}-1} \leq \frac{1}{500C} \quad (41)$$

is valid with $C > 0$ such that (38) (Proposition 5.8) holds, then there exists some $s \in [r_1/2, r_1]$ such that $\#\Sigma \cap \partial B_s(x_0) = 2$.

(iii) If both (39) and (41) hold, and $r \in [r_1/2, r_1]$ is such that $\#\Sigma \cap \partial B_r(x_0) = 2$, then

(iii-1) the two points of $\Sigma \cap \partial B_r(x_0)$ belong to two different connected components of the set $\partial B_r(x_0) \cap \{y : \text{dist}(y, P_0) \leq \beta_\Sigma(x_0, r)r\}$, where P_0 is a straight line that provides the infimum in the definition of $\beta_\Sigma(x_0, r)$,

(iii-2) $\Sigma \cap \overline{B}_r(x_0)$ is connected,

(iii-3) assuming additionally that $B_{r_1}(x_0) \subset \Omega$ and denoting $\{a_1, a_2\} = \Sigma \cap \partial B_r(x_0)$, we have

$$\mathcal{H}^1(\Sigma \cap B_r(x_0)) \leq |a_2 - a_1| + Cr \left(\frac{r}{r_1}\right)^{\frac{1}{2}} \omega_\Sigma(x_0, r_1) + Cr_1^{\frac{2}{p'}}.$$

Remark 5.11. It is easy to see from the proof that for an internal point $x_0 \in \Omega$ one can take $r_\Omega := +\infty$. Thus if one applies this result only to internal points of Ω , then the requirement that $\Omega \subset \mathbb{R}^2$ be a C^1 domain is unnecessary.

Remark 5.12. In the sequel, when the situation of item (iii-1) will occur we will say, in short, that the two points lie “on both sides”.

Proof. Every ball in this proof is centered at x_0 unless otherwise explicitly stated. We first prove (i). Let us construct a competitor in B_r for any fixed $r \in [r_1/2, r_1]$. Let x_1 and x_2 be the two points of $\partial B_r \cap P_0$ and let W be the small “wall” defined by

$$W := \partial B_r \cap \{x : d(x, P_0) \leq 2r\beta_\Sigma(x_0, r)\}.$$

We consider two cases.

CASE A: $B_r \subset \Omega$. Then consider the competitor (see Figure 5.2)

$$\Sigma' := (\Sigma \setminus B_r) \cup W \cup [x_1, x_2].$$

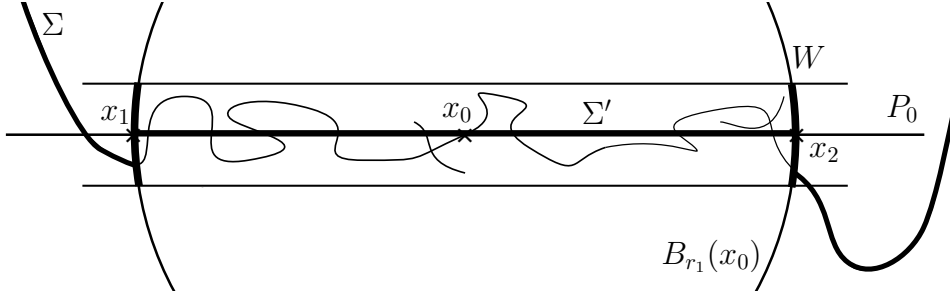

Figure 5.2: The competitor Σ' in the proof Proposition 5.10 (i) case one.

It is easily seen that Σ' is a compact connected set satisfying $\Sigma \Delta \Sigma' \subset \overline{B}_r$. Since Σ is a minimizer, we have

$$\mathcal{H}^1(\Sigma) \leq \mathcal{H}^1(\Sigma') + E(u_\Sigma) - E(u_{\Sigma'}),$$

and thus

$$\begin{aligned} \mathcal{H}^1(\Sigma \cap B_r) &\leq 2r + \mathcal{H}^1(W) + E(u_\Sigma) - E(u_{\Sigma'}) \\ &\leq 2r + \mathcal{H}^1(W) + Cr \left(\frac{r}{r_1}\right)^{\frac{1}{2}} \omega_\Sigma(x_0, r_1) + Cr_1^{\frac{2}{p'}} \quad \text{by Proposition 5.8.} \end{aligned} \quad (42)$$

On the other hand,

$$\mathcal{H}^1(W) \leq 4r \arcsin(\beta_\Sigma(x_0, r)) \leq 10r\beta_\Sigma(x_0, r), \quad (43)$$

the latter inequality coming from the assumption $\beta_\Sigma(x_0, r) \leq 1/10$ minding that $|\arcsin'(z)| \leq 2$ for all $z \in [0, 1/10]$. The estimate (42) combined with (43) implies (i) in the case $B_r \subset \Omega$.

CASE B: $\partial\Omega \cap B_r \neq \emptyset$. Notice that, since x_0 may be very close to $\partial\Omega$, the competitor Σ' as before might not be contained in $\bar{\Omega}$, and therefore we need to modify it in this situation. Letting $z \in \partial\Omega \cap B_r$ we have $B_r \subset B_{2r}(z)$. Moreover, since Ω is a C^1 domain, and in particular $\partial\Omega$ is compact, we can argue as in the proof of Lemma 3.5 to find $r_\Omega > 0$ such that $\partial\Omega$ is very flat in all balls of radius less than r_Ω , uniformly on $\partial\Omega$; in other words, $\beta_{\partial\Omega}(x, s) \leq 10^{-10}/2$ for all $x \in \partial\Omega$ and all $s \leq 2r_\Omega$. This means, since $2r \leq 2r_\Omega$, that $\partial\Omega \cap B_{2r}(z)$ is localized in a very thin strip of height $\delta := 4 \cdot 10^{-10}r$ centered at z . Let us assume that this strip is oriented in the \mathbf{e}_1 direction and that Ω is situated below (i.e. touching the region $\{x_2 < 0\}$). Our aim is to translate locally Σ' a little downwards, to insure that it lies in Ω . For this purpose we construct a bi-Lipschitz mapping Φ , equal to Id outside $B_{r(1+\delta)}$, and equal to $-\delta r \mathbf{e}_2$ in B_r which will guarantee that $\Phi(\Sigma') \subset \bar{\Omega}$ (see Figure 5.3).

More precisely, we let $\varphi : \mathbb{R}^+ \rightarrow [0, \delta r]$ be a 1-Lipschitz function, equal to 0 on $[r(1+\delta), +\infty)$, and to $r\delta$ on $[0, r]$, and define $\Phi : \mathbb{R}^2 \rightarrow \mathbb{R}^2$ as follows

$$\Phi(x) = \text{Id} - \varphi(|x - x_0|)\mathbf{e}_2.$$

We notice that Φ is 2-Lipschitz and maps $B_{r(1+\delta)}$ into itself. Next, we define as before the compact connected set

$$\Sigma' := (\Sigma \setminus B_r) \cup (W \cap \bar{\Omega}) \cup [x_1, x_2],$$

and then the translated one

$$\Sigma'' := \Phi(\Sigma') \subset \bar{\Omega}.$$

The set Σ'' is still compact and connected and we observe

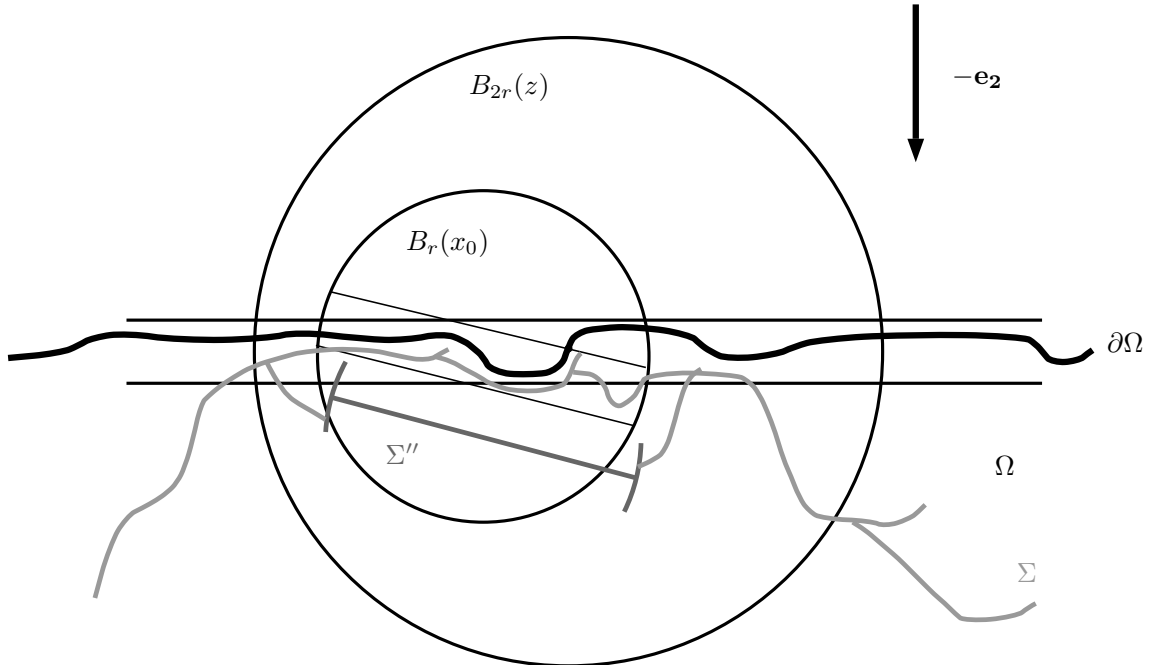

Figure 5.3: The competitor Σ'' in the proof Proposition 5.10 (i), Case B.

$$\Sigma'' \setminus B_{r(1+\delta)} = \Sigma' \setminus B_{r(1+\delta)} = \Sigma \setminus B_{r(1+\delta)}.$$

Now we estimate $\mathcal{H}^1(\Sigma'' \cap B_{r(1+\delta)})$. To this aim we decompose

$$B_{r(1+\delta)} = \Phi(\overline{B}_r) \cup \Phi(B_{r(1+\delta)} \setminus \overline{B}_r).$$

On B_r , the mapping Φ is just a translation so that

$$\mathcal{H}^1(\Sigma'' \cap \Phi(B_r)) = \mathcal{H}^1(\Phi(\Sigma' \cap B_r)) = \mathcal{H}^1(\Sigma' \cap B_r),$$

hence using (43) we get

$$\mathcal{H}^1(\Sigma'' \cap \Phi(B_r)) \leq 2r + 10r\beta_\Sigma(x_0, r).$$

On the other hand, since Φ is 2-Lipschitz,

$$\begin{aligned} \mathcal{H}^1(\Sigma'' \cap \Phi(B_{r(1+\delta)} \setminus \overline{B}_r)) &= \mathcal{H}^1(\Phi(\Sigma' \cap B_{r(1+\delta)} \setminus \overline{B}_r)) \\ &\leq 2\mathcal{H}^1(\Sigma' \cap B_{r(1+\delta)} \setminus \overline{B}_r) \\ &= 2\mathcal{H}^1(\Sigma \cap B_{r(1+\delta)} \setminus \overline{B}_r) \\ &\leq 4rC_0\beta_\Sigma(x_0, 2r), \end{aligned}$$

where C_0 is the upper Ahlfors regularity constant of Σ , because $\Sigma \cap B_{r(1+\delta)} \setminus \overline{B}_r$ is localized in the union of two balls of radius bounded by $2r\beta_\Sigma(x_0, 2r)$.

Finally, thanks to (39) we still have $\beta_{\Sigma''}(x_0, r(1+\delta)) \leq 1/10$, so that Proposition 5.8 applies. Since Σ is a minimizer, we have

$$\mathcal{H}^1(\Sigma) \leq \mathcal{H}^1(\Sigma'') + E(u_\Sigma) - E(u_{\Sigma''}),$$

and thus using Proposition 5.8 (applied with $(1+\delta)r$ instead of r and Σ'' instead of Σ'), we infer that

$$\begin{aligned} \mathcal{H}^1(\Sigma \cap B_r) &\leq \mathcal{H}^1(\Sigma'' \cap B_{r(1+\delta)}) - \mathcal{H}^1(\Sigma \cap B_{r(1+\delta)} \setminus B_r) + E(u_\Sigma) - E(u_{\Sigma''}) \\ &\leq \mathcal{H}^1(\Sigma'' \cap B_{r(1+\delta)}) + E(u_\Sigma) - E(u_{\Sigma''}) \\ &\leq 2r + 10r\beta_\Sigma(x_0, r) + 4rC_0\beta_\Sigma(x_0, 2r) + Cr \left(\frac{r}{r_1}\right)^{\frac{1}{2}} \omega_\Sigma(x_0, r_1) + Cr_1^{\frac{2}{p'}} \\ &\leq 2r + (20 + 4C_0)r\beta_\Sigma(x_0, 2r) + Cr \left(\frac{r}{r_1}\right)^{\frac{1}{2}} \omega_\Sigma(x_0, r_1) + Cr_1^{\frac{2}{p'}}, \end{aligned}$$

where in the last inequality (26) has been used. This concludes the proof of (i) also in case (B).

To prove (ii), we use Lemma 5.3 (with $\varepsilon := 10^{-4}$, and $r_0 := 10^{-3}r_1$) which implies that

$$\mathcal{H}^1(\{s \in [10^{-3}r_1, r_1] : \#\Sigma \cap \partial B_s < 2\}) \leq 2 \cdot 10^{-4}r_1. \quad (44)$$

Next, applying (i) with $r := r_1$, we get, thanks to our conditions on r_1 and $\omega_\Sigma(x, r_1)$, the estimate

$$\mathcal{H}^1(\Sigma \cap B_{r_1}) \leq (2 + 3/100)r_1. \quad (45)$$

We will use the following Eilenberg inequality ([16, 2.10.25] or [11, Section 26, Lemma 1, p. 160]):

$$\mathcal{H}^1(\Sigma \cap B_{r_1}) \geq \int_0^{r_1} \#\Sigma \cap \partial B_s ds. \quad (46)$$

Let us define three sets

$$\begin{aligned} E_1 &:= \{s \in [0, r_1] : \#\Sigma \cap \partial B_s = 1\}, E_2 := \{s \in [0, r_1] : \#\Sigma \cap \partial B_s = 2\}, \\ E_3 &:= \{s \in [0, r_1] : \#\Sigma \cap \partial B_s \geq 3\}. \end{aligned}$$

In particular, (44) says that $\mathcal{H}^1(E_1) \leq 10^{-3}r_1 + 2 \cdot 10^{-4}r_1 \leq 10^{-2}r_1$, and hence, using also (45) and (46) we deduce that

$$\begin{aligned} (2 + 3/100)r_1 &\geq \mathcal{H}^1(E_1) + 2\mathcal{H}^1(E_2) + 3\mathcal{H}^1(E_3) \\ &= \mathcal{H}^1(E_1) + 2(r_1 - \mathcal{H}^1(E_3) - \mathcal{H}^1(E_1)) + 3\mathcal{H}^1(E_3) \\ &= -\mathcal{H}^1(E_1) + 2r_1 + \mathcal{H}^1(E_3), \end{aligned}$$

from which we get

$$\mathcal{H}^1(E_3) \leq \frac{3r_1}{100} + \mathcal{H}^1(E_1) \leq \frac{4r_1}{100} < \frac{r_1}{2},$$

and therefore $E_2 \cap [r_1/2, r_1] \neq \emptyset$.

It remains to prove (iii). We argue in a similar way, but now since $\Sigma \cap \partial B_r = \{a_1, a_2\}$, i.e. $\#\Sigma \cap \partial B_r = 2$, the “wall” set W is no more needed to make a competitor, so we get a better estimate by taking as a competitor a replacement of Σ by just a segment inside B_r joining the two points a_1 and a_2 , which leads to the estimate in (iii-3).

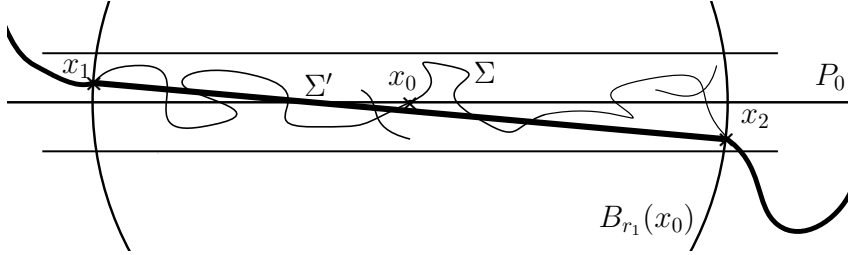

Figure 5.4: The competitor Σ' in the proof Proposition 5.10 (iii).

Thus we only need to prove (iii-1) and (iii-2). Let us first prove (iii-1). Supposing the contrary, we could take as a competitor the set

$$\Sigma' := (\Sigma \setminus B_r) \cup (W \cap \bar{\Omega})$$

where W is a small “wall” on one side of length less than $10r\beta_\Sigma(x, r_1)$. This would imply

$$\begin{aligned} r \leq \mathcal{H}^1(\Sigma \cap B_r) &\leq 10r\beta_\Sigma(x, r) + Cr \left(\frac{r}{r_1}\right)^{\frac{1}{2}} \omega_\Sigma(x, r_1) + Cr_1^{\frac{2}{p'}} \\ &\leq \frac{r}{100} + \frac{r}{100} + \frac{r}{100}, \end{aligned} \quad (47)$$

hence a desired contradiction.

To prove (iii-2), we note that by Lemma 5.13 below (with $D := B_r \cap \Sigma$), if $\Sigma \cap \bar{B}_r$ is not connected, then the set $\Sigma \setminus B_r$ has to be connected. It follows that $\Sigma \setminus B_r$ is a competitor, and as before, comparing the energy of Σ and $\Sigma' := \Sigma \setminus B_r$ leads to

$$r \leq \mathcal{H}^1(\Sigma \cap B_r) \leq 2r/100, \quad (48)$$

which is the desired contradiction. Thus we have proven that (iii-2) holds true, so that the proof of (iii) is concluded. \square

Lemma 5.13. *If Σ is an arcwise connected metric space, $D \subset \Sigma$ is an open subset, and \bar{D} is not arcwise connected, but $\#\partial D = 2$, then the set $\Sigma \setminus D$ is arcwise connected.*

Proof. Let $\partial D := \{a_1, a_2\}$, and consider an arbitrary couple of points $\{z_1, z_2\} \subset \Sigma \setminus D$ and an arc $\Gamma \subset \Sigma$ that connects z_1 and z_2 . Then either $\Gamma \cap \bar{D} = \emptyset$, in which case $\Gamma \cap D = \emptyset$, or $\#\Gamma \cap \bar{D} = 1$, in which case again $\Gamma \cap D = \emptyset$ (because Γ enters into \bar{D} through, say, a_1 , but it cannot enter D , since then it must exit through the same point a_1 , which is impossible by injectivity of Γ), or else $\Gamma \cap \bar{D} = \{a_1, a_2\}$, so that Γ enters \bar{D} at, say a_1 and exits at, say a_2 . In this last case this means that there exists a curve in \bar{D} that connects a_1 to a_2 , but then since any other point in \bar{D} is connected to z_1 by some curve, that passes necessarily through either a_1 or a_2 , this means that \bar{D} is arcwise connected. \square

5.3 Flatness estimates

We begin with a standard flatness estimate on curves coming just from Pythagoras' theorem.

Lemma 5.14. *Let Γ be an arc in $\bar{B}_r(x_0)$ satisfying $\beta_\Gamma(x_0, r) \leq 1/10$, and which connects two points $x_1, x_2 \in \partial B_r(x_0)$ lying on both sides (as defined in Remark 5.12). Then*

$$\text{dist}(z, [x_1, x_2])^2 \leq 2r(\mathcal{H}^1(\Gamma) - |x_2 - x_1|), \quad \text{for all } z \in \Gamma. \quad (49)$$

Proof. Assume that z is the most distant point from the segment $[x_1, x_2]$ in Γ and let z' be the point making (x_1, x_2, z') an isosceles triangle with same height that we denote $h =: \text{dist}(z, [x_1, x_2])$, see Figure 5.5. Let $a := |x_2 - x_1|/2$ and $\ell := |z' - x_1|$. We have that

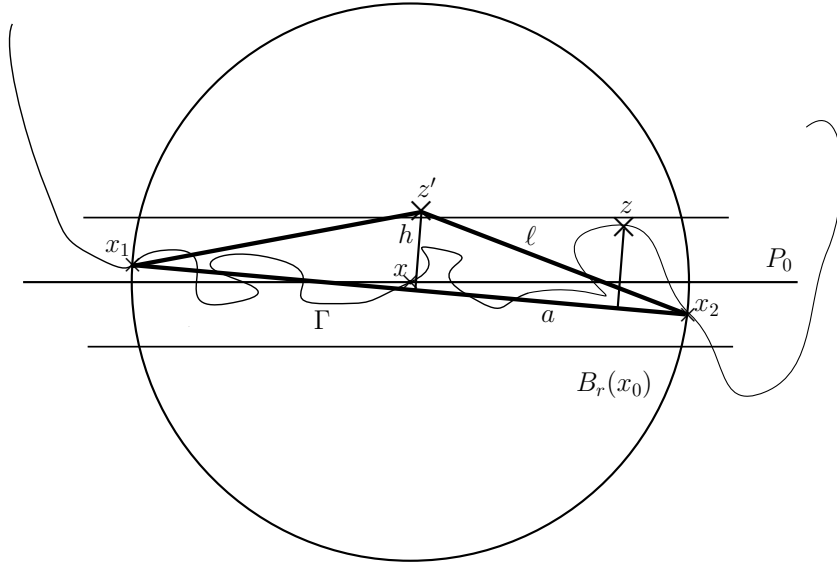

Figure 5.5: Flatness estimate.

$$h^2 = \ell^2 - a^2 = (\ell - a)(\ell + a).$$

On the other hand $\mathcal{H}^1(\Gamma) \geq 2\ell$, so that

$$h^2 \leq \frac{1}{2}(\mathcal{H}^1(\Gamma) - |x_1 - x_2|)(\ell + a).$$

But now since $\beta_\Gamma(x_0, r) \leq 1/10$, it is easily seen that $\ell \leq r\sqrt{1 + \frac{1}{10^2}} \leq r\sqrt{101}/10 \leq 2r$ and $a \leq r$, so the Lemma follows. \square

Remark 5.15. Notice that, contrary to the similar statements that sometimes can be found in the literature, Lemma 5.14 would not be true, if one replaces the arc Γ by an arbitrary closed arcwise connected set Σ . Indeed, in an arbitrary arcwise connected set Σ , the arc connecting x_1 to z and the arc connecting z to x_2 may overlap, so that the sum of the lengths of both curves may not be smaller than the length of Σ . Anyway, in the next proposition, we will apply this lemma in a minimizer Σ (which is not a priori an injective curve) as follows: we first find an arc in Σ connecting x_1 to x_2 and control the distance of that curve to the segment $[x_1, x_2]$. Therefore, this arc has length at least $|x_1 - x_2|$ and we will control the distance of the remaining parts of Σ to $[x_1, x_2]$ by a density estimate which will say that the total length of those small “forgotten” pieces is very small (thus, by connectedness, very close in distance as well).

We now can prove the existence of a threshold for which β stays small at smaller scales as soon as it is small at one scale.

Proposition 5.16. *Let $\Omega \subset \mathbb{R}^2$, $f \in L^p(\Omega)$ with $p > 2$, $\Sigma \subset \overline{\Omega}$ be a minimizer, and C_0 be its upper Ahlfors regularity constant. Then there exist numbers τ_1, τ_2 with $0 < \tau_2 < \tau_1 < \frac{10^{-5}}{20+4C_0}$ and $r_0 \in (0, \text{diam}(\Sigma)/2)$ such that whenever $x \in \Sigma$ and $0 < r < r_0$ satisfy $B_r(x) \subset \Omega$ and*

$$\beta_\Sigma(x, r) \leq \tau_1, \quad \omega_\Sigma(x, r) \leq \tau_2, \quad (50)$$

then

(i) (50) also holds with $r/16$ instead of r .

(ii)

$$\omega_\Sigma(x, r/256) \leq \frac{1}{2}\omega_\Sigma(x, r) + Cr^{\frac{2}{p}-1}$$

(iii)

$$\beta_\Sigma(x, r/4) \leq C(\omega_\Sigma(x, r))^{\frac{1}{2}} + Cr^{\frac{1}{p}-\frac{1}{2}}$$

with $C = C(|\Omega|, p, \|f\|_p) > 0$.

Proof. We first fix r_0 and τ_2 small enough so that

$$\tau_2 + r_0^{\frac{2}{p}-1} \leq \frac{1}{1000C}, \quad (51)$$

where C appears in Proposition 5.8, and we also assume that

$$256Cr_0^{\frac{2}{p}-1} \leq \frac{\tau_2}{2}. \quad (52)$$

Take an arbitrary $r \in (0, r_0)$ as in the statement. We have $\beta_\Sigma(x_0, r) \leq \tau_1 \leq 1/512$ (so that $r/256 \geq 2\tau_1 r$) and $r < \text{diam}(\Sigma)/2$. This allows to apply Proposition 5.7 with $r/256$ and r in place of r and r_1 respectively, and $\tau_1 < 1/10$ in place of ε getting

$$\omega_\Sigma(x, r/256) \leq 8 \left(\frac{1}{256} \right)^{\frac{1}{2}} \omega_\Sigma(x, r) + 256Cr^{\frac{2}{p}-1},$$

which proves (ii). The proof of (i) will be accomplished as soon as we prove (iii) because

$$\beta_\Sigma(x, r/16) \leq 4\beta_\Sigma(x, r/4) \leq C\sqrt{\tau_2} + Cr_0^{\frac{1}{p}-\frac{1}{2}} \leq \tau_1,$$

provided that we choose τ_2 and r_0 small enough with respect to τ_1 .

Next, recalling (51), we apply Proposition 5.10 (ii) in order to find some $s \in [r/4, r/2]$ such that $\#\Sigma \cap \partial B_s = 2$ (notice indeed that $\beta_\Sigma(x, r) \leq 10^{-5}/(20 + 4C_0)$ and all the assumptions of Proposition 5.10 are fulfilled with x, r instead of x_0, r_1 respectively). Then assertion (iii) of Proposition 5.10 says that the two points a_1 and a_2 of $\Sigma \cap \partial B_s(x)$ must lie on both sides, and $B_s(x) \cap \Sigma$ is connected. Moreover, Proposition 5.10 (iii-3) says

$$\begin{aligned} \mathcal{H}^1(\Sigma \cap B_s(x)) &\leq |a_2 - a_1| + Cs \left(\frac{s}{r}\right)^{\frac{1}{2}} \omega_\Sigma(x, r) + Cr^{\frac{2}{p'}} \\ &=: |a_2 - a_1| + R. \end{aligned} \quad (53)$$

Let $\Gamma \subset \Sigma \cap \overline{B}_s(x)$ be an injective curve that connects a_1 and a_2 . Lemma 5.14 (with s instead of r) says that

$$\begin{aligned} \sup_{z \in \Gamma} \text{dist}(z, [a_1, a_2])^2 &\leq 2s(\mathcal{H}^1(\Gamma) - |a_2 - a_1|) \\ &\leq 2sR. \end{aligned} \quad (54)$$

Now, since $\mathcal{H}^1(\Gamma) \geq |a_2 - a_1|$ we also get from (53) that

$$\mathcal{H}^1(\Sigma \cap B_s(x) \setminus \Gamma) \leq R.$$

But this implies

$$\sup_{z \in \Sigma \cap B_s(x) \setminus \Gamma} \text{dist}(z, \Gamma) \leq R, \quad (55)$$

so that from

$$\text{dist}(z, [a_1, a_2]) \leq \text{dist}(z, \Gamma) + \sup_{z' \in \Gamma} \text{dist}(z, [a_1, a_2])$$

recalling (54) and (55) we get

$$\sup_{z \in \Sigma \cap B_s(x)} \text{dist}(z, [a_1, a_2]) \leq \sqrt{2sR} + R \leq \sqrt{2rR} + R. \quad (56)$$

By connectedness of $\Sigma \cap B_s(x)$ we have that for every $z \in [a_1, a_2]$ the line perpendicular to $[a_1, a_2]$ at z must meet $\Sigma \cap B_s(x)$, and therefore from (56) we get

$$\sup_{z \in [a_1, a_2]} \text{dist}(z, \Sigma) \leq \sqrt{2rR} + R.$$

Thus we have proven that

$$s\beta_\Sigma(x, s) \leq 2(\sqrt{2rR} + R)$$

(we have lost a further factor 2 because $[a_1, a_2]$ may not be passing through x). But then

$$\beta_\Sigma\left(x, \frac{r}{4}\right) \leq 2\beta_\Sigma(x, s) \leq \frac{4}{s}(\sqrt{2rR} + R).$$

Let us estimate the right hand side, with the constant $C > 0$ possibly changing from line to line

$$\begin{aligned} R &= Cs \left(\frac{s}{r}\right)^{\frac{1}{2}} \omega_\Sigma(x, r) + Cr^{\frac{2}{p'}} \\ &\leq Cr\omega_\Sigma(x, r) + Cr^{\frac{2}{p'}} \quad (\text{because } s \leq r/2) \\ &\leq Cr(\omega_\Sigma(x, r))^{\frac{1}{2}} + Cr^{\frac{1}{p'} + \frac{1}{2}} \end{aligned} \quad (57)$$

the latter inequality being due to $\omega_\Sigma(x, r) \leq 1$, $r \leq 1$ and $\frac{1}{p'} > \frac{1}{2}$. Moreover, from (57) we get

$$\sqrt{2rR} \leq Cr(\omega_\Sigma(x, r))^{\frac{1}{2}} + Cr^{\frac{1}{p'} + \frac{1}{2}}.$$

This concludes the proof of (iii), and so the proof of the Proposition follows. \square

Now we iterate the last proposition to obtain the following one.

Proposition 5.17. *Let $\Omega \subset \mathbb{R}^2$, $f \in L^p(\Omega)$ with $p > 2$, $\Sigma \subset \bar{\Omega}$ be a minimizer. There exist numbers τ_1, τ_2 with $0 < \tau_2 < \tau_1$ and positive $\bar{r}_0, C, \delta, \gamma$ such that whenever $x \in \Sigma$ and $r_0 \leq \bar{r}_0$ satisfy $B_{r_0}(x) \subset \Omega$ and*

$$\beta_\Sigma(x, r_0) \leq \tau_1, \quad \omega_\Sigma(x, r_0) \leq \tau_2, \quad (58)$$

then

$$\omega_\Sigma(x, r) \leq C \left(\frac{r}{r_0} \right)^{\frac{1}{4}} \tau_2 + Cr^\gamma \quad \text{for all } r \in (0, r_0/2) \quad (59)$$

and

$$\beta_\Sigma(x, r) \leq C\sqrt{\tau_2} \left(\frac{r}{r_0} \right)^{\frac{1}{8}} + Cr^\delta \quad \text{for all } r \in (0, r_0/8). \quad (60)$$

for some C depending on $|\Omega|, p, \|f\|_p$.

Proof. Let $\bar{r}_0, \tau_2, \tau_1, \gamma > 0, C > 0$ be the constants given by Proposition 5.16. Fix $a := 1/256$. By multiple applications of Proposition 5.16 we know that

$$\beta_\Sigma(x, a^n r_0) \leq \tau_1 \quad \text{and} \quad \omega_\Sigma(x, a^n r_0) \leq \tau_2 \quad \text{for all } n \geq 0.$$

We first prove by induction that for all $n \in \mathbb{N}$ we have, for some $\gamma > 0$,

$$\omega_\Sigma(x, a^n r_0) \leq \frac{1}{2^n} \omega_\Sigma(x, r_0) + C(a^n r_0)^\gamma. \quad (61)$$

Let us fix $\alpha := \frac{2}{p} - 1 > 0$ and define

$$\gamma := \min \left(\frac{\alpha}{2}, \frac{-\ln(3/4)}{\ln(256)} \right), \quad t_0 := \left(\frac{1}{4} \right)^{\frac{1}{\gamma}}.$$

This choice of constants α, γ, t_0 has been made to guarantee that

$$\frac{1}{2} t^\gamma + t^\alpha \leq (at)^\gamma \quad \text{for all } t \in (0, t_0). \quad (62)$$

To check (62), we use that $\alpha \geq 2\gamma$ by definition and $t \in (0, t_0)$ with $t_0 \leq 1$ to estimate

$$\frac{1}{2} t^\gamma + t^\alpha \leq \frac{1}{2} t^\gamma + t_0^\gamma t^\gamma \leq \frac{3}{4} t^\gamma \leq \left(\frac{1}{256} \right)^\gamma t^\gamma = (at)^\gamma$$

because $\gamma \leq -\frac{\ln(3/4)}{\ln(256)}$ implies $\frac{3}{4} \leq \left(\frac{1}{256} \right)^\gamma$.

It is clear that (61) holds for $n = 0$. Assume now that (61) holds for some n and by choosing \bar{r}_0 smaller assume that $\bar{r}_0 \leq t_0$. Applying Proposition 5.16 (ii) in $B_{a^n r_0}(x)$ yields

$$\begin{aligned} \omega_\Sigma(x, a^{n+1} r_0) &\leq \frac{1}{2} \omega_\Sigma(x, a^n r_0) + C(a^n r_0)^\alpha \\ &\leq \frac{1}{2} \left(\frac{1}{2^n} \omega_\Sigma(x, r_0) + C(a^n r_0)^\gamma \right) + C(a^n r_0)^\alpha \\ &\leq \frac{1}{2^{n+1}} \omega_\Sigma(x, r_0) + C(a^{n+1} r_0)^\gamma, \end{aligned}$$

concluding the proof of (61).

Now let $r \in [0, r_0/2]$. Then $a^{n+1}r_0 \leq r \leq a^n r_0$ for some n , and using (36),

$$\begin{aligned}
\omega_\Sigma(x, r) &\leq 256\omega_\Sigma(x, a^n r_0) \leq 256\left(\frac{1}{2}\right)^n \omega_\Sigma(x, r_0) + 256C(a^n r_0)^\gamma \\
&\leq 256\left(\frac{1}{256}\right)^{\frac{n}{4}} \omega_\Sigma(x, r_0) + 256^{1+\gamma}Cr^\gamma \\
&\leq 256^2\left(\frac{r}{r_0}\right)^{\frac{1}{4}} \omega_\Sigma(x, r_0) + 256^{1+\gamma}Cr^\gamma.
\end{aligned} \tag{63}$$

Now that ω_Σ decays, we can prove a similar decay for β_Σ . Let $\alpha' := \frac{1}{p'} - \frac{1}{2}$. Then applying Proposition 5.16 (iii) in $B_{a^n r_0}(x)$ and using (59) we get

$$\begin{aligned}
\beta_\Sigma(x, a^n r_0/4) &\leq C(\omega_\Sigma(x, a^n r_0))^{\frac{1}{2}} + C(a^n r_0)^{\alpha'} \\
&\leq C\left(256^2\tau_2 a^{\frac{n}{4}} + C(a^n r_0)^\gamma\right)^{\frac{1}{2}} + C(a^n r_0)^{\alpha'} \\
&\leq C\sqrt{256^2\tau_2} a^{\frac{n}{8}} + \sqrt{C}(a^n r_0)^{\frac{\gamma}{2}} + C(a^n r_0)^{\alpha'}.
\end{aligned}$$

Now let $r \in [0, r_0/2]$ and choose n such that $a^{n+1}r_0 \leq r \leq a^n r_0$. Then

$$\begin{aligned}
\beta_\Sigma(x, r/4) &\leq 16\beta_\Sigma(x, a^n r_0/4) \\
&\leq C\sqrt{\tau_2} a^{\frac{n}{8}} + Cr^{\frac{\gamma}{2}} + Cr^{\alpha'} \\
&\leq C\sqrt{\tau_2} a^{\frac{n}{8}} + Cr^{\frac{\gamma}{2}} + Cr^{\alpha'} \\
&\leq C\sqrt{\tau_2}\left(\frac{r}{r_0}\right)^{\frac{1}{8}} + Cr^{\frac{\gamma}{2}} + Cr^{\alpha'}.
\end{aligned}$$

We finish the proof by setting $\delta := \max(\frac{\gamma}{2}, \alpha')$. □

Corollary 5.18. *Let $\Omega \subset \mathbb{R}^2$, $f \in L^p(\Omega)$ with $p > 2$, $\Sigma \subset \bar{\Omega}$ be a minimizer. There exist positive numbers ε_0 and \bar{r}_0, C, α such that whenever $x \in \Sigma$ and $r_0 \leq \bar{r}_0$ satisfy $B_{r_0}(x) \subset \Omega$ and*

$$\beta_\Sigma(x, r_0) + \omega_\Sigma(x, r_0) \leq \varepsilon_0,$$

then there is an $\alpha \in (0, 1)$ so that the estimate

$$\beta_\Sigma(y, r) \leq Cr^\alpha \quad \text{for all } y \in \Sigma \cap B_{r_0/2}(x) \text{ and } r \in (0, r_0/16) \tag{64}$$

holds true. In particular, $\Sigma \cap B_{r_0/4}(x)$ is a $C^{1,\alpha}$ regular curve.

Proof. To get (64), fix $\varepsilon_0 := \tau_2/4$ where τ_2 is defined in Proposition 5.17, and apply the Proposition 5.17 with $y \in \Sigma \cap B_{r_0/2}(x)$ and $r_0/2$ instead of x_0 and r_0 respectively, after noticing that $\beta_\Sigma(y, r_0/2) \leq 4\beta_\Sigma(x, r_0)$ and $\omega_\Sigma(y, r_0/2) \leq 4\omega_\Sigma(x, r_0)$. Then it is quite standard to prove that (64) implies $C^{1,\alpha}$ -regularity of Σ (see, e.g. the proof of corollary 5.33 from [11]). □

Note that at this point, using the uniform rectifiability of Σ and a standard compactness argument, it would not be very difficult to prove that Σ is $C^{1,\alpha}$ regular outside of a set of Hausdorff dimension $d < 1$. We will not proceed in this direction because the blow-up analysis of the next section will actually prove much more, namely that $d = 0$.

We finish this section by a last statement saying that Corollary 5.18 still holds at the boundary, if the domain is convex.

Proposition 5.19. *Let $\Omega \subset \mathbb{R}^2$ be convex, $f \in L^p(\Omega)$ with $p > 2$, $\Sigma \subset \bar{\Omega}$ be a minimizer. Then we can find $\varepsilon_0 > 0$ and positive constants \bar{r}_0, C, α such that whenever $x \in \Sigma \cap \partial\Omega$ and $r_0 \leq \bar{r}_0$ are such that, u_Σ being extended by zero outside Ω ,*

$$\beta_\Sigma(x, r_0) + \omega_\Sigma(x, r_0) \leq \varepsilon_0$$

then there is an $\alpha \in (0, 1)$ such that

$$\beta_\Sigma(y, r) \leq Cr^\alpha \quad \text{for all } y \in \Sigma \cap B_{r_0/2}(x) \text{ and } r \in (0, r_0/16). \quad (65)$$

In particular, $\Sigma \cap B_{r_0/4}(x)$ is a $C^{1,\alpha}$ regular curve.

Proof. If Ω is convex, then Problem 1.1 is exactly the same if we relax the class of competitors

$$\{\Sigma \subset \bar{\Omega}, \text{ closed and connected}\}$$

by

$$\{\Sigma \subset \mathbb{R}^2, \text{ closed and connected}\}.$$

Indeed, the projection P_Ω onto Ω is 1-Lipschitz, and thus minimizing on the second class would lead to the same minimizers since the projection of any competitor does not increase the value of \mathcal{F} . This means that, in the case of convex domains, we may consider Σ as a subset of \mathbb{R}^2 with competitors in \mathbb{R}^2 , and consider $u_\Sigma \in H_0^1(\Omega \setminus \Sigma)$ as a function of $H^1(\mathbb{R}^2)$ extending it by zero outside Ω , and then one can follow the whole Section 5 line by line and check that it works at the boundary straight away. □

Remark 5.20. A consequence of Proposition 5.19 is that, if Ω is convex and C^1 but its boundary is nowhere $C^{1,\alpha}$, then Σ will never want to stay inside $\partial\Omega$ for a while because it would contradict the $C^{1,\alpha}$ regularity. In this case it can only touch $\partial\Omega$ pointwise.

6 Blow-up limits of minimizers and first consequences

6.1 Convergence of blow-up sequences for interior points

Throughout this section, let Σ denote a minimizer for the Problem 1.1, and $u := u_\Sigma$. Let $\{x_n\} \subset \Sigma$ be a sequence of points and $r_n \rightarrow 0^+$ as $n \rightarrow \infty$. We define the blow-up sequence by

$$\Sigma_n := \frac{1}{r_n}(\Sigma - x_n), \quad \Omega_n := \frac{1}{r_n}(\Omega - x_n), \quad (66)$$

$$u_n(x) := r_n^{-\frac{1}{2}}u(r_nx + x_n) \in H_0^1(\Omega_n \setminus \Sigma_n). \quad (67)$$

Our scaling implies that

$$\int_{\Omega_n} |\nabla u_n|^2 dx + \mathcal{H}^1(\Sigma_n) = \frac{1}{r_n} \int_{\Omega} |\nabla u|^2 dx + \frac{1}{r_n} \mathcal{H}^1(\Sigma).$$

It follows that, for all n , the couple (u_n, Σ_n) is a minimizer in Ω_n for the optimal compliance problem associated to the function

$$f_n(x) := r_n^{3/2}f(r_nx + x_n).$$

For a given closed set $\Sigma \subset \mathbb{R}^2$ we define the subspace $H_{0,\Sigma,loc}^1(\mathbb{R}^2)$ of $H_{loc}^1(\mathbb{R}^2)$ consisting of functions vanishing on Σ , by setting

$$H_{0,\Sigma,loc}^1(\mathbb{R}^2) := \{u \in H_{loc}^1(\mathbb{R}^2) : \varphi_R u \in H_0^1(B_R(0) \setminus \Sigma) \text{ for all } R > 0\}, \quad (68)$$

where φ_R is the Lipschitz cut-off function $\varphi_R(x) := \max(R - |x|, 0)$.

Proposition 6.1. *Assume that $f \in L^p(\Omega)$, $p > 2$, $x_n \rightarrow x_0 \in \Sigma \cap \Omega$. Then there exist some closed set $\Sigma_0 \subset \mathbb{R}^2$, a function $u_0 \in H_{0,\Sigma_0,loc}^1(\mathbb{R}^2)$, and a subsequence $r_{n_k} \rightarrow 0$ such that (u_{n_k}, Σ_{n_k}) converges to (u_0, Σ_0) in the following way: for every ball $B \subset \mathbb{R}^2$,*

(i) $\Sigma_{n_k} \rightarrow \Sigma_0$ in the Kuratowski sense in \mathbb{R}^2 , and, moreover, $(\Sigma_{n_k} \cap B) \cup \partial B \rightarrow (\Sigma_0 \cap B) \cup \partial B$ in the Hausdorff distance in \mathbb{R}^2 ,

(ii) $u_{n_k} \rightarrow u_0$ strongly in $H^1(B)$.

In addition, u_0 is harmonic in $\mathbb{R}^2 \setminus \Sigma_0$.

Proof. For simplicity we will not relabel subsequences. We first extract a subsequence so that (i) holds. To this aim, let us stress that, in general, if a sequence of sets converge in the Hausdorff distance, then their restrictions to subsets may not converge. This is why the notion of local Hausdorff converging sequence in \mathbb{R}^2 is delicate (see [11]) and we will not try to make $\Sigma_n \cap B$ converging to $\Sigma_0 \cap B$ for every ball in the Hausdorff distance. Instead, we start by using Blaschke principle in the Alexandrov one-point compactification of \mathbb{R}^2 , to extract a subsequence of Σ_n converging to some set Σ_0 in the compactified space. This implies the convergence of Σ_n in the Kuratowski sense in the compactified space, hence also in \mathbb{R}^2 , and it also implies that, for every ball $B \subset \mathbb{R}^2$, $(\Sigma_n \cap B) \cup \partial B \rightarrow (\Sigma_0 \cap B) \cup \partial B$ in the classical Hausdorff distance (in fact, it clearly converges in Kuratowski sense, and hence in Hausdorff distance because $(\Sigma_n \cap B) \cup \partial B$ are all included in the same compact set \overline{B}).

We now claim that

(S) for every ball $B = B_R(0) \subset \mathbb{R}^2$ one may extract a further subsequence (depending on B) such that for some $u_0 \in H^1(B)$ harmonic in $B \setminus \Sigma_0$ and satisfying $\varphi u_0 \in H_0^1(B \setminus \Sigma_0)$ for all $\varphi \in C_0^\infty(B)$, one has $u_n \rightarrow u_0$ strongly in $L^2(B)$ and $\nabla u_n \rightarrow \nabla u_0$ strongly in $L^2(B_{R/2}; \mathbb{R}^2)$.

To show claim (S), use first the change of variables $y = r_n x + x_n$ to get

$$\int_B |\nabla u_n|^2 dx = \frac{1}{r_n} \int_{B_{Rr_n}(x_n)} |\nabla u_n|^2 dy \leq C,$$

where $C > 0$ depends only on $\|f\|_p$ and R , the latter estimate being due to Lemma 3.3 applied with $\gamma = 2\pi$ (see Remark 3.4). Together with the Poincaré inequality (Lemma A.1) this implies

$$\|u_n\|_{H^1(B)} \leq C,$$

where still $C = C(\|f\|_p, R) > 0$. This means that, up to a subsequence, $u_n \rightharpoonup u_0$ weakly in $H^1(B)$ for some $u_0 \in H^1(B)$ (hence strongly in $L^2(B)$). This shows that $\varphi u_0 \in H_0^1(B \setminus \Sigma_0)$ for any Lipschitz function φ vanishing on ∂B (see Remark 2.4).

It is easy to verify that $-\Delta u_0 = 0$ in $B \setminus \Sigma_0$ because, for all $\varphi \in C_0^\infty(B \setminus \Sigma_0)$, the Hausdorff convergence of Σ_n implies that $\varphi \in C_0^\infty(B \setminus \Sigma_n)$ for all sufficiently large $n \in \mathbb{N}$ and therefore

$$\int_\Omega \nabla u_n \cdot \nabla \varphi dx = \int_\Omega \varphi f_n dx. \quad (69)$$

Passing to the limit in n and recalling that $f_n \rightarrow 0$ strongly in $L^2(B)$, $\nabla u_n \rightharpoonup \nabla u$ weakly in $L^2(B)$, we infer that

$$\int_\Omega \nabla u_0 \cdot \nabla \varphi dx = 0, \quad \text{for all } \varphi \in C_0^\infty(B \setminus \Sigma_0)$$

i.e. u_0 is harmonic in $\mathbb{R}^2 \setminus \Sigma_0$.

Let φ be a 2-Lipschitz cut-off function equal to 1 on $B_{(3/4)R}$ and zero outside of B , and consider the truncated function φu_0 , that is equal to u_0 on $B_{(3/4)R}$ and zero on ∂B . Note that $\varphi u_0 \in H_0^1(B \setminus \Sigma_0)$. Since $\tilde{\Sigma}_n := (\Sigma_n \cap B) \cup \partial B$ is connected for all $n \in \mathbb{N}$ and converges with respect to the Hausdorff distance in \bar{B} to $(\Sigma_0 \cap B) \cup \partial B$, by the convergence of $H_0^1(B \setminus \tilde{\Sigma}_n)$ to $H_0^1(B \setminus \Sigma)$ in the sense of Mosco (in view of Remark 2.4, namely, since for all $u \in H_0^1(B \setminus \Sigma)$ there is a sequence $\{u_n\} \subset H_0^1(B \setminus \tilde{\Sigma}_n)$ converging to u in $H^1(B)$), we obtain the existence of a sequence $\{\tilde{u}_n\} \subset H_0^1(B \setminus \tilde{\Sigma}_n)$ converging to φu_0 strongly in $H^1(B)$. In particular, $\tilde{u}_n \rightarrow u_0$ strongly in $H^1(B_{(3/4)R})$.

To prove that $\nabla u_n \rightarrow \nabla u_0$ strongly in $L^2(B_{R/2}; \mathbb{R}^2)$, it suffices, in view of the weak convergence of $\nabla u_n \rightharpoonup \nabla u_0$ in $L^2(B_{R/2}; \mathbb{R}^2)$, to prove $\|\nabla u_n\|_{L^2(B_{R/2})} \rightarrow \|\nabla u_0\|_{L^2(B_{R/2}; \mathbb{R}^2)}$ which in turn reduces to proving

$$\int_{B_{R/2}} |\nabla u_0|^2 dx \geq \limsup_n \int_{B_{R/2}} |\nabla u_n|^2 dx, \quad (70)$$

because the opposite inequality for \liminf is automatic from weak convergence. To prove (70), consider also another cut-off function ψ satisfying, for a parameter $0 < s < 1/2$,

$$\psi(x) = \begin{cases} 1 & \text{on } B_{R/2}, \\ 0 & \text{outside } (1+s)B_{R/2}, \\ \text{linear in } |x| & \text{otherwise,} \end{cases}$$

and set

$$w_n := \psi \tilde{u}_n + (1 - \psi)u_n.$$

Since u_n is a minimizer of

$$u \in H_0^1(\Omega_n \setminus \Sigma_n) \mapsto \int_{\Omega_n} |\nabla u|^2 dx - 2 \int_{\Omega_n} u f_n dx,$$

and since w_n is a competitor, we obtain

$$\int_{\Omega_n} |\nabla u_n|^2 dx - 2 \int_{\Omega_n} u_n f_n dx \leq \int_{\Omega_n} |\nabla w_n|^2 dx - 2 \int_{\Omega_n} w_n f_n dx,$$

thus, since $w_n = u_n$ outside $(1+s)B_{R/2}$,

$$\int_{(1+s)B_{R/2}} |\nabla u_n|^2 dx - 2 \int_{(1+s)B_{R/2}} u_n f_n dx \leq \int_{(1+s)B_{R/2}} |\nabla w_n|^2 dx - 2 \int_{(1+s)B_{R/2}} w_n f_n dx. \quad (71)$$

Let us compute

$$\nabla w_n = \psi \nabla \tilde{u}_n + (1 - \psi) \nabla u_n + (\tilde{u}_n - u_n) \nabla \psi,$$

which yields, denoting by $H_n := \psi \nabla \tilde{u}_n + (1 - \psi) \nabla u_n$, the relationship

$$|\nabla w_n|^2 = |H_n|^2 + |\tilde{u}_n - u_n|^2 |\nabla \psi|^2 + 2H_n \cdot (\tilde{u}_n - u_n) \nabla \psi.$$

Integrating over $C_s := (1+s)B_{R/2} \setminus B_{R/2}$ and recalling that $\nabla w_n = \nabla \tilde{u}_n$ in $B_{R/2}$, we can write (71) in the form

$$\int_{(1+s)B_{R/2}} |\nabla u_n|^2 dx \leq \int_{B_{R/2}} |\nabla \tilde{u}_n|^2 dx + \int_{C_s} |H_n|^2 dx + R_n, \quad (72)$$

where

$$R_n := 2 \int_{(1+s)B_{R/2}} (u_n - w_n) f_n dx + \int_{C_s} |\tilde{u}_n - u_n|^2 |\nabla \psi|^2 + 2H_n \cdot (\tilde{u}_n - u_n) \nabla \psi dx.$$

By the convexity of $|\cdot|^2$ we get the inequality

$$|H_n|^2 \leq \psi |\nabla \tilde{u}_n|^2 + (1 - \psi) |\nabla u_n|^2,$$

so that (72) becomes

$$\begin{aligned} \int_{(1+s)B_{R/2}} |\nabla u_n|^2 dx &\leq \int_{B_{R/2}} |\nabla \tilde{u}_n|^2 dx + R_n \\ &+ \int_{C_s} \psi |\nabla \tilde{u}_n|^2 dx + \int_{C_s} (1 - \psi) |\nabla u_n|^2 dx, \end{aligned}$$

and in view of $\psi \leq 1$ we finally get

$$\int_{B_{R/2}} |\nabla u_n|^2 dx \leq \int_{(1+s)B_{R/2}} |\nabla \tilde{u}_n|^2 dx + R_n. \quad (73)$$

Notice now that $R_n \rightarrow 0$, because all the functions \tilde{u}_n, u_n, w_n converge strongly in $L^2((1+s)B)$ to the same function u_0 , the sequence $\{H_n\}$ is uniformly bounded in $L^2(C_s) \subset L^2(B)$, and $f_n \rightarrow 0$ in $L^2((1+s)B) \subset L^2(B)$. Therefore, passing to the limsup in (73) and using the strong convergence of \tilde{u}_n to u_0 in $H^1((1+s)B_{R/2}) \subset H^1(3/4B)$, we get

$$\limsup_n \int_{B_{R/2}} |\nabla u_n|^2 dx \leq \int_{(1+s)B_{R/2}} |\nabla u_0|^2 dx,$$

which gives (70) by taking the limit in $s \rightarrow 0^+$, hence completing the proof of strong convergence of ∇u_n to ∇u in $L^2(B_{R/2})$ and therefore concluding the proof of claim (S).

Finally, once the claim (S) is proven, it suffices to choose for each $m \in \mathbb{N}$ a subsequence $\{n(m, j)\}_j \subset \mathbb{N}$ such that $\{n(m+1, j)\}_j \subset \{n(m, j)\}_j$ and each sequence $\{u_{n(m, j)}\}_j$ is convergent strongly some function in $L^2(B_{2m})$ with the sequence of gradients $\{\nabla u_{n(m, j)}\}_j$ convergent strongly to the gradient of the same function in $L^2(B_m(x_0); \mathbb{R}^2)$, with the limit function as in claim (S) (with B_{2m} instead of B). Taking the diagonal sequence $\{u_{n(m, m)}\}_m$ we have that there is a $u_0 \in H_{loc}^1(\mathbb{R}^2)$ harmonic in $\mathbb{R}^2 \setminus \Sigma_0$ such that $\varphi u_0 \in H_0^1(B_R \setminus \Sigma_0)$ for every $R > 0$ and φ vanishing over ∂B_R , with $\{u_{n(m, m)}\}_m$ convergent strongly to u in $L^2(B_R)$ and the sequence of gradients $\{\nabla u_{n(m, m)}\}_m$ convergent strongly to u in $L^2(B_R; \mathbb{R}^2)$. This completes the proof of (ii). \square

6.2 Two compactness estimates

The goal of this section is to prove that, as soon as $\beta_\Sigma(x, r)$ with $x \in \Sigma$ is small enough, then all the assumptions of the C^1 regularity result are satisfied. To this aim we need to control the energy ω_Σ of u from the flatness β_Σ , and this is done in the following proposition via a compactness argument.

Proposition 6.2. *Assume that $f \in L^p(\Omega)$, $p > 2$, Σ is a minimizer of Problem 1.1 and let $x \in \Sigma \cap \Omega$ be such that $\beta_\Sigma(x, r) \xrightarrow{r \rightarrow 0^+} 0$. Then*

$$\frac{1}{r} \int_{B_r(x)} |\nabla u_\Sigma|^2 dx \xrightarrow{r \rightarrow 0^+} 0. \quad (74)$$

Proof. The balls in this proof are all centered in x unless otherwise stated. By Remark 3.4 we know that the limit in (74) exists, and is finite. Assume by contradiction that the limit is equal to some $C > 0$. Then by considering the blow-up sequence $u_\Sigma(r_n y + x)/\sqrt{r_n}$ we know that it converges as $r_n \rightarrow 0$ in \mathbb{R}^2 , to some harmonic function u_0 in the complement of a line,

with $u_0 = 0$ on that line. By the strong convergence in $H_{loc}^1(\mathbb{R}^2)$ we infer that u_0 has constant normalized Dirichlet energy, equal to C , in other words

$$\int_{B_R} |\nabla u_n|^2 dx = \frac{1}{r_n} \int_{B_{Rr_n}} |\nabla u_\Sigma|^2 dx \rightarrow RC,$$

thus

$$\frac{1}{R} \int_{B_R} |\nabla u_0|^2 dx = C \quad \text{for all } R > 0. \quad (75)$$

But then considering u_0^+ the restriction of u_0 on one side of the line, one can extend it as a harmonic function \tilde{u}_0 in the whole \mathbb{R}^2 using a reflexion. This function still satisfies (75) and by the mean value property together with Jensen's inequality one finds that for all $x \in \mathbb{R}^2$ and $R > 0$,

$$\begin{aligned} |\nabla \tilde{u}_0|^2 &\leq \frac{1}{\pi R^2} \int_{B_R(x)} |\nabla \tilde{u}_0(y)|^2 dy \\ &\leq \frac{1}{\pi R^2} \int_{B_{R+|x|}(0)} |\nabla \tilde{u}_0(y)|^2 dy \leq \frac{C}{\pi} \frac{R+|x|}{R^2}, \end{aligned}$$

where the last inequality follows from (75). Sending $R \rightarrow +\infty$ one obtains $\nabla \tilde{u}_0(x) = 0$, a contradiction (an alternative argument would be to use the decomposition of u into spherical harmonics, like in [22, Theorem 15]). \square

Then we control $\omega_\Sigma(x, r)$ from $\int_{B_r(x)} |\nabla u_\Sigma|^2$ by another compactness argument.

Proposition 6.3. *Assume that $f \in L^p(\Omega)$, $p > 2$, and let $C > 0$ be the constant of Remark 3.4 (depending only on $|\Omega|$, $\|f\|_p$, p). Then for every $r_0 \in (0, \text{diam}(\Sigma)/2)$ there exists a $\rho \in (0, 1)$ such that for any $x \in \Sigma$ we have*

$$\omega_\Sigma(x, \rho r_0) \leq \frac{2}{r_0} \int_{B_{r_0}(x)} |\nabla u_\Sigma|^2 dx + C r_0^{\frac{2}{p'}-1}.$$

Proof. If the claim is false, one can find an $r_0 \in (0, \text{diam}(\Sigma)/2)$ and two sequences $\rho_n \rightarrow 0$, $\{x_n\} \subset \Sigma$ such that

$$\omega_\Sigma(x_n, \rho_n r_0) > \frac{2}{r_0} \int_{B_{r_0}(x_n)} |\nabla u_\Sigma|^2 dx + C r_0^{\frac{2}{p'}-1}.$$

This implies in particular the existence of a sequence of compact connected maximizers $\Sigma_n \subset \bar{\Omega}$ for ω_Σ such that $\Sigma_n \Delta \Sigma \subset \bar{B}_{\rho_n r_0}(x_n)$ and

$$\frac{1}{\rho_n r_0} \int_{B_{\rho_n r_0}(x_n)} |\nabla u_{\Sigma_n}|^2 dx > \frac{2}{r_0} \int_{B_{r_0}(x_n)} |\nabla u_\Sigma|^2 dx + C r_0^{\frac{2}{p'}-1}. \quad (76)$$

From Remark 3.4 applied with Σ_n and x_n instead of Σ and x_0 respectively, we get

$$\frac{1}{r_0} \int_{B_{r_0}(x_n)} |\nabla u_{\Sigma_n}|^2 dx \geq \frac{1}{\rho_n r_0} \int_{B_{\rho_n r_0}(x_n)} |\nabla u_{\Sigma_n}|^2 dx + C(\rho_n r_0)^{\frac{2}{p'}-1} - C r_0^{\frac{2}{p'}-1},$$

which together with (76) gives for an arbitrary $\varepsilon > 0$ the estimate

$$\frac{1}{r_0} \int_{B_{r_0+\varepsilon}(x_0)} |\nabla u_{\Sigma_n}|^2 dx \geq \frac{1}{r_0} \int_{B_{r_0}(x_n)} |\nabla u_{\Sigma_n}|^2 dx > \frac{2}{r_0} \int_{B_{r_0}(x_n)} |\nabla u_\Sigma|^2 dx + C(\rho_n r_0)^{\frac{2}{p'}-1}$$

for all sufficiently large n (depending on ε). Then passing to the limit (up to a subsequence) $x_n \rightarrow x_0$, $\Sigma_n \rightarrow \Sigma_0$ (which necessarily equals Σ) and applying Šverák Theorem 2.3 we get

$$\frac{1}{r_0} \int_{B_{r_0+\varepsilon}(x_0)} |\nabla u_\Sigma|^2 dx \geq \frac{2}{r_0} \int_{B_{r_0}(x_0)} |\nabla u_\Sigma|^2 dx,$$

and then passing to a limit in $\varepsilon \rightarrow 0^+$ we arrive at a contradiction. \square

6.3 Flat points are C^1 -points

A first consequence of the above compactness estimates is the following statement that we will need later.

Theorem 6.4. *Assume that $f \in L^p(\Omega)$, $p > 2$, and let Σ be a minimizer of Problem 1.1. There exist an $\varepsilon > 0$ and an $a \in (0, 1)$ such that, if $x \in \Sigma$ is such that $B_r(x) \subset \Omega$ and*

$$\beta_\Sigma(x, r) \leq \varepsilon,$$

then $\Sigma \cap B(x, ar)$ is a $C^{1,\alpha}$ curve for some $\alpha \in (0, 1)$. As a consequence, for any point $x \in \Sigma \cap \Omega$ which admits a line as blow-up limit, there exists $r > 0$ such that $\Sigma \cap B_r(x)$ is a $C^{1,\alpha}$ curve.

Proof. From Proposition 6.2 and Proposition 6.3 we deduce that, provided ε is small enough, one can find r_0 such that both $\beta_\Sigma(x, r_0)$ and $\omega_\Sigma(x, r_0)$ are small enough to apply Corollary 5.18. \square

For some technical reasons we will also need the following more precise version of the above statement, which is just a rephrasing of some of the previous results, and that will be needed only in the proof of Proposition 6.7.

Lemma 6.5. *Assume that $f \in L^p(\Omega)$, $p > 2$ and let Σ be a minimizer of Problem 1.1. There exist numbers $\varepsilon_0 \in (0, 1/100)$, $\delta > 0$ and $r_0 > 0$ such that whenever $x \in \Sigma$ and $10r \leq \min(r_0, d(x, \partial\Omega))$ are such that*

$$\beta_\Sigma(x, 10r) \leq \varepsilon_0,$$

then $B_r(x) \cap \Sigma$ is a $C^{1,\alpha}$ curve for some $\alpha \in (0, 1)$ satisfying in addition

$$\beta_\Sigma(x, t) \leq \varepsilon_0, \tag{77}$$

$$\int_{B_t(x)} |\nabla u_\Sigma|^2 dx \leq \left(\frac{t}{r}\right)^{1+\delta} \left(\int_{B_r(x)} |\nabla u_\Sigma|^2 dx + Cr^{\frac{2}{p'}} \right) \tag{78}$$

for all $t < r$ and for some $C > 0$ depending on $|\Omega|$, $\|f\|_p$, p . Moreover, for any $t < r$ there exists an $s \in [t/2, t]$ such that $\#\Sigma \cap \partial B_s(x) = 2$ with the points lying on both sides.

Proof. The first part of the claim, (77) and the conclusion about the existence of $s \in [t/2, t]$ such that $\#\Sigma \cap \partial B_s(x) = 2$, are directly coming from the proof of Theorem 6.4 (and from the proofs of previous propositions used for the proof of the later). But then this allows us to apply the monotonicity Lemma 3.3, which says that

$$\int_{B_t(x)} |\nabla u_\Sigma|^2 dx \leq \left(\frac{t}{r}\right)^\alpha \left(\int_{B_r(x)} |\nabla u_\Sigma|^2 dx + Cr^{\frac{2}{p'}} \right) \quad \text{for all } t < r$$

with $\alpha = 2\pi/\gamma_\Sigma(x, 0, r)$. Indeed, we may assume that $\frac{2}{p'} - \frac{2\pi}{\gamma_\Sigma(x, 0, r)} > 0$ provided that ε_0 is small enough (with respect to p). Thus (78) follows by setting $\delta := 1 - \frac{2\pi}{\gamma_\Sigma(x, 0, r)}$. \square

Remark 6.6. Though it will not be used, under the assumptions of Lemma 6.5 we also have by Proposition 5.17 that

$$\frac{1}{t} \int_{B_t(x)} |\nabla u_\Sigma|^2 dx \leq \omega_\Sigma(x, t) \leq C \left(\frac{t}{r}\right)^{\frac{1}{4}} + Ct^\delta \quad \text{for all } t < r,$$

but in the sequel we really need the slightly different version (78).

6.4 Chord-arc estimate and connectedness of blow-up limits

Let $d_\Sigma(x, y)$ be the geodesic distance in Σ . We would like to prove the following.

Proposition 6.7. *Assume that $f \in L^p(\Omega)$, $p > 2$. Let Ω be a C^1 domain and let $\Sigma \subset \bar{\Omega}$ be a minimizer of Problem 1.1. Then there exists $C > 0$ (depending on Σ) such that*

$$d_\Sigma(x, y) \leq C|x - y| \quad \text{for all } x, y \in \Sigma. \quad (79)$$

Remark 6.8. As it will be clear from the proof, without any condition on the boundary of Ω one would have that (79) holds with C depending on the distance between $\{x, y\}$ and $\partial\Omega$.

The proof of Proposition 6.7 uses the uniform rectifiability of the minimizer Σ , and will be used later to prove that blow-up limits of minimizers are connected sets. It also needs some well known facts about uniformly rectifiable sets. Here is the exact statement that we will use.

Proposition 6.9. *For any $C > 0$ and $\varepsilon > 0$ there exists $c_0 \in (0, 1)$ depending only on C and ε , such that the following holds. Let K be a compact connected set which is Ahlfors-regular with constants C , and let $\Gamma \subset K$ be a curve. Then for any $x \in \Gamma$ and $r < \min(1, \text{diam}(\Gamma))$, there exists a ball $B_s(y) \subset B_r(x)$ such that $y \in \Gamma$, $s \geq c_0 r$ and*

$$\beta_K(y, s) \leq \varepsilon.$$

Proof. The statement is classical in uniform rectifiability theory, but here we stress that the ball $B_s(y)$ where $\beta_K(y, s)$ is small is centered on $y \in \Gamma$, a given sub curve of K . The proof follows by the same classical argument but we prefer to give the full details since it may not be as standard as when one wants $y \in K$.

Since K is compact, connected, and Ahlfors-regular, then it is a uniformly rectifiable set, in other words contained in an Ahlfors-regular curve [11, Theorem 31.5]. Consequently, the set K satisfies the so-called BWGL (Bilateral Weak Geometric Lemma [13, Definition 2.2, p. 32]), which means the following. For any $\varepsilon > 0$ let us consider the bad set

$$\mathcal{B}_\varepsilon := \{(x, t) \in K \times (0, 1] : \beta_K(x, t) > \varepsilon\}.$$

Then there exists some $C_\varepsilon > 0$ such that

$$\int_{K \cap B_t(x)} \int_0^t \mathbf{1}_{\mathcal{B}_\varepsilon}(y, s) \frac{ds}{s} d\mathcal{H}^1(y) \leq C_\varepsilon t \quad \text{for all } (x, t) \in K \times (0, 1]. \quad (80)$$

Now let us consider the set

$$\mathcal{B}'_\varepsilon := \{(x, t) \in \Gamma \times (0, 1] : \beta_K(x, t) > \varepsilon\} \subset \mathcal{B}_\varepsilon.$$

Of course $\mathbf{1}_{\mathcal{B}'_\varepsilon} \leq \mathbf{1}_{\mathcal{B}_\varepsilon}$ thus we readily have from (80)

$$\int_{\Gamma \cap B_t(x)} \int_0^t \mathbf{1}_{\mathcal{B}'_\varepsilon}(y, s) \frac{ds}{s} d\mathcal{H}^1(y) \leq C_\varepsilon t \quad \text{for all } (x, t) \in \Gamma \times (0, 1].$$

Now letting $r_1 := \min(1, \text{diam}(\Gamma))$ we argue by contradiction and assume, for some given $(x, t) \in \Gamma \times (0, r_1)$, that $\beta_K(y, s) > \varepsilon$ for all $s \in (ct, t/2)$, and for all $y \in \Gamma \cap B_{t/2}(x)$, where $c > 0$ has to be chosen later. Since Γ is a curve, $x \in \Gamma$ and since $t/2 < \text{diam}(\Gamma)$ we have

$$\mathcal{H}^1(\Gamma \cap B_{t/2}(x)) \geq \frac{t}{2}.$$

Therefore,

$$C_\varepsilon t \geq \int_{\Gamma \cap B_t(x)} \int_0^t \mathbf{1}_{B_\varepsilon}(y, s) \frac{ds}{s} d\mathcal{H}^1(y) \geq \int_{\Gamma \cap B_{t/2}(x)} \int_{ct}^{t/2} \frac{ds}{s} d\mathcal{H}^1(y) \geq \frac{t}{2} \log \frac{1}{2c},$$

which provides a contradiction if we chose $c > 0$ small enough compared to C_ε . \square

We can now prove Proposition 6.7.

Proof of Proposition 6.7. We argue by contradiction. We already know that Σ is Ahlfors regular with upper constant C_0 . Let $r_0, \varepsilon_0, \delta > 0$ be the constants of Proposition 6.5 while c_0 is the constant given by Proposition 6.9 with the choice $\varepsilon := \varepsilon_0$.

Assume now that for some $\{x, y\} \subset \Sigma$ with $R := |x - y|$ small enough, any geodesic curve $\Gamma \subset \Sigma$ connecting them satisfies

$$\mathcal{H}^1(\Gamma) > \Lambda C_0 R, \quad (81)$$

where $\Lambda > 0$ is a large constant that will be fixed during the proof. Namely, Λ will first be chosen large enough, and then R will be taken sufficiently small, depending in particular on this large Λ . Let us now proceed to the proof.

First we notice that $\Gamma \setminus B_{\Lambda R}(x)$ is not empty, because otherwise we would have $\Gamma \subset B_{\Lambda R}(x)$ which would imply $\mathcal{H}^1(\Gamma) \leq C_0 \Lambda R$ by Ahlfors regularity of Σ , a contradiction with (81). Since Γ is a curve containing x , we deduce that there exists a $z \in \Gamma$ such that

$$\Lambda R/2 < |x - z| \leq \Lambda R. \quad (82)$$

If R is small enough we have that $\Lambda R/2 < 1$ and the first inequality in (82) implies $\Lambda R/2 < \text{diam}(\Gamma)$, which allows us to apply Proposition 6.9 to find a ball $B_{10s_0}(z') \subset B_{\Lambda R/2}(z)$ with s_0 satisfying $c_0 \Lambda R/20 \leq s_0 \leq \Lambda R/20$ and

$$\beta_\Sigma(z', 10s_0) \leq \varepsilon_0.$$

Now we distinguish two cases.

CASE A: $B_{10s_0}(z') \subset \Omega$. Then, assuming $\Lambda R < r_0$, we can apply Proposition 6.5 with z' and s_0 in place of x and r respectively. This implies

$$\beta_\Sigma(z', t) \leq \varepsilon_0 \quad \text{for all } t \leq s_0$$

and

$$\int_{B_t(z')} |\nabla u_\Sigma|^2 dx \leq \left(\frac{t}{s_0}\right)^{1+\delta} \left(\int_{B_{s_0}(z')} |\nabla u_\Sigma|^2 dx + C s_0^{\frac{2}{p'}} \right) \quad \text{for all } t \leq s_0 \quad (83)$$

with $C > 0$ independent of t and s_0 . In the sequel we will still denote by C a constant that may change from line to line. Then, we consider t satisfying $2R \leq t \leq 4R$ and such that $\sharp \Sigma \cap \partial B_t(z') = 2$ with the points lying on both sides (this is possible by the last conclusion of Proposition 6.5 and by assuming $\Lambda > 4$ so that $4R \leq \Lambda R < r_0$). Then we take the competitor

$$\Sigma' := (\Sigma \setminus B_t(z')) \cup [x, y],$$

it is easy to verify that Σ' is connected. In addition, one has

$$\mathcal{H}^1(\Sigma) - \mathcal{H}^1(\Sigma') \geq \mathcal{H}^1(\Sigma \cap B_t(z')) - |x - y| \geq t - R \geq R. \quad (84)$$

Now let $\tilde{\Sigma} = \Sigma \setminus B_t(z')$, so that $\tilde{\Sigma} \Delta \Sigma \subset B_t(z')$ and $\tilde{\Sigma} \subset \Sigma'$. Since $H_0^1(\Omega \setminus \Sigma') \subset H_0^1(\Omega \setminus \tilde{\Sigma})$ and since $u_{\tilde{\Sigma}}$ minimizes E over $H_0^1(\Omega \setminus \tilde{\Sigma})$, we have $E(u_{\tilde{\Sigma}}) \leq E(u_{\Sigma'})$ which in turn says that

$$\int_{\Omega} |\nabla u_{\Sigma'}|^2 dx \leq \int_{\Omega} |\nabla u_{\tilde{\Sigma}}|^2 dx.$$

Therefore, using that Σ is a compliance minimizer and that Σ' is a competitor, we can write

$$\begin{aligned} \mathcal{H}^1(\Sigma) &\leq \mathcal{H}^1(\Sigma') + \int_{\Omega} |\nabla u_{\Sigma'}|^2 dx - \int_{\Omega} |\nabla u_{\Sigma}|^2 dx \\ &\leq \mathcal{H}^1(\Sigma') + \int_{\Omega} |\nabla u_{\tilde{\Sigma}}|^2 dx - \int_{\Omega} |\nabla u_{\Sigma}|^2 dx \\ &\leq \mathcal{H}^1(\Sigma') + C \int_{B_t(z')} |\nabla u_{\Sigma}|^2 dx + Ct^{\frac{2}{p'}}, \text{ by Lemmas 3.1 and 3.6,} \end{aligned} \quad (85)$$

with $C > 0$ independent of t .

Plugging (84) into (85), using (83) and the fact that $c_0 \Lambda R/20 \leq s_0 \leq \Lambda R/20$ and $2R \leq t \leq 4R$, we obtain

$$\begin{aligned} R \leq \mathcal{H}^1(\Sigma) - \mathcal{H}^1(\Sigma') &\leq C \left(\frac{t}{s_0} \right)^{1+\delta} \left(\int_{B_{s_0}(z')} |\nabla u_{\Sigma}|^2 dx + Cs_0^{\frac{2}{p'}} \right) + Ct^{\frac{2}{p'}} \\ &\leq C \left(\frac{1}{\Lambda} \right)^{1+\delta} \left(\int_{B_{s_0}(z')} |\nabla u_{\Sigma}|^2 dx + Cs_0^{\frac{2}{p'}} \right) + CR^{\frac{2}{p'}}. \end{aligned} \quad (86)$$

Next we apply Remark 3.4 (monotonicity with $\gamma = 2\pi$) to get the following estimate, denoting also by $d_0 = \text{diam}(\Sigma)/2$,

$$\int_{B_{s_0}(z')} |\nabla u_{\Sigma}|^2 dx \leq s_0 \left(\frac{1}{d_0} \int_{B_{d_0}(z')} |\nabla u_{\Sigma}|^2 dx + Cd_0^{\frac{2}{p'}-1} \right) \quad (87)$$

$$\leq s_0 \left(\frac{1}{d_0} \int_{\Omega} |\nabla u_{\Sigma}|^2 dx + Cd_0^{\frac{2}{p'}-1} \right) =: Cs_0. \quad (88)$$

Returning to (86) and using that $s_0 \leq \Lambda R/20$ we have now obtained

$$R \leq C \left(\frac{1}{\Lambda} \right)^{1+\delta} \left(s_0 + s_0^{\frac{2}{p'}} \right) + CR^{\frac{2}{p'}} \leq C \left(\frac{1}{\Lambda} \right)^{1+\delta} \left(\Lambda R + (\Lambda R)^{\frac{2}{p'}} \right) + CR^{\frac{2}{p'}}.$$

By choosing now Λ sufficiently large so that $C \frac{1}{\Lambda^\delta} \leq \frac{1}{2}$ we get

$$R/2 \leq C(\Lambda R)^{\frac{2}{p'}}.$$

Finally, recalling that $2/p' > 1$ we obtain a contraction for R sufficiently small.

CASE B: there exists a $z'' \in B_{10s_0}(z') \cap \partial\Omega$. Then $B_{s_0}(z') \subset B_{20s_0}(z'')$. Let $r_0 := r_0(\partial\Omega, |\Omega|, p, \|f\|_p)$ be as in Lemma 3.5, and assuming that $\Lambda R \leq r'_0 \leq r_0$, we can apply Lemma 3.5 which implies

$$\int_{B_{s_0}(z')} |\nabla u_{\Sigma}|^2 dx \leq \int_{B_{20s_0}(z'')} |\nabla u_{\Sigma}|^2 dx \leq C \left(\frac{R}{r'_0} \right)^{1+\delta}, \quad (89)$$

where $C > 0$ is independent of R . We can also assume, taking r'_0 sufficiently small, that the assumptions (39) of Proposition 5.10 is satisfied, and considering R small enough, the assumption (41) of Proposition 5.10 is also satisfied, thanks to (89). This allows us to find $s \in [s_0/4, s_0/2]$ such that $\sharp\Sigma \cap \partial B_s(z') = 2$ with the points lying on both sides. We then continue as in Case A, namely, we take the competitor

$$\Sigma' := (\Sigma \setminus B_s(z')) \cup \Gamma_{x,y},$$

where $\Gamma_{x,y}$ is the geodesic curve in $\bar{\Omega}$ that connects x and y . Since Ω is a C^1 domain, we have

$$\mathcal{H}^1(\Gamma_{x,y}) \leq R + o(R)$$

as $R \rightarrow 0^+$. Therefore, if R is small enough, and using that $s \geq s_0/4 \geq c_0\Lambda R/40$,

$$\mathcal{H}^1(\Sigma) - \mathcal{H}^1(\Sigma') \geq \mathcal{H}^1(\Sigma \cap B_s(z')) - R - o(R) \geq s - 2R \geq c_0\Lambda R/40 - 2R \geq R, \quad (90)$$

provided that $\Lambda c_0 \geq 120$. Now arguing exactly as for (85) with s instead of t we get the estimate

$$\begin{aligned} \mathcal{H}^1(\Sigma) &\leq \mathcal{H}^1(\Sigma') + \int_{\Omega} |\nabla u_{\Sigma'}|^2 dx - \int_{\Omega} |\nabla u_{\Sigma}|^2 dx \\ &\leq \mathcal{H}^1(\Sigma') + \int_{\Omega} |\nabla u_{\Sigma \setminus B_s(z')}|^2 dx - \int_{\Omega} |\nabla u_{\Sigma}|^2 dx \\ &\leq \mathcal{H}^1(\Sigma') + C \int_{B_{2s}(z')} |\nabla u_{\Sigma}|^2 dx + Cs^{\frac{2}{p'}}, \text{ by Lemmas 3.1 and 3.6.} \end{aligned} \quad (91)$$

Then using (89), (90) and (91) we get

$$R \leq C \int_{B_{s_0}(z'')} |\nabla u_{\Sigma}|^2 dx + Cs_0^{\frac{2}{p'}} \leq C \left(\frac{R}{r'_0} \right)^{1+\delta} + CR^{\frac{2}{p'}},$$

which yields again a contradiction for R small enough.

This means that for some $R_0 > 0$, once $x, y \in \Sigma$ satisfy $|x - y| \leq R_0$, then the geodesic curve $\Gamma \subset \Sigma$ connecting them does not satisfy (81), or, in other words, that (79) holds for any such couple of points. But if $|x - y| \geq R_0$ we obviously have that

$$d_{\Sigma}(x, y) \leq \mathcal{H}^1(\Sigma) \leq \frac{\mathcal{H}^1(\Sigma)}{R_0} |x - y|,$$

which concludes the proof. □

One of the main purposes of proving the chord-arc estimate is to obtain the following consequence.

Proposition 6.10. *The set Σ_0 given by Proposition 6.1 is an unbounded arcwise connected set, and any connected component of $\mathbb{R}^2 \setminus \Sigma_0$ is simply connected.*

Proof. Let Σ be a minimizer for Problem 1.1. We first prove that Σ_0 is connected. Let x and y be two arbitrary points in Σ_0 , and set $R := |x| + 2|x - y|$. Since $\Sigma_n \rightarrow \Sigma$ in the Hausdorff distance in $B_R(0)$, we can find two sequences $x_n \rightarrow x$ and $y_n \rightarrow y$ satisfying $\{x_n, y_n\} \subset \Sigma_n$ for all $n \in \mathbb{N}$. Let $\Gamma_n \subset \Sigma_n$ be a geodesic curve connecting x_n to y_n in Σ_n . By Proposition 6.7 there exists a constant $C > 0$ (depending only on Σ) such that

$$\mathcal{H}^1(\Gamma_n) \leq C|x - y|,$$

and hence $\Gamma_n \subset \overline{B_{CR}}(0)$. We can therefore extract a subsequence such that $\Gamma_n \rightarrow \Gamma$ in Hausdorff distance for some compact connected $\Gamma \subset \overline{B_{CR}}(0)$. But then Γ is a connected set contained in Σ_0 which necessarily contains x and y . Since x and y were arbitrary, we have that Σ_0 is a connected set.

It is also quite clear that Σ_0 must be unbounded because $\text{diam}(\Sigma_n) \rightarrow +\infty$ and Σ_n converges to Σ_0 in the sense of Kuratowski. It remains to prove that any connected component of $\mathbb{R}^2 \setminus \Sigma_0$ is simply connected. Let U be a connected component of $\mathbb{R}^2 \setminus \Sigma_0$, and let $\Gamma \subset U$ be a simple closed curve. Without loss of generality, we may assume that this curve is polygonal. Since Γ is a Jordan curve, $\mathbb{R}^2 \setminus \Gamma$ has two connected components, A^- and A^+ . Let A^- be the bounded one. Since Σ_0 is unbounded, we must have $\Sigma_0 \cap A^+ \neq \emptyset$. And since Σ_0 is connected, we must have $\Sigma_0 \subset A^+$, because otherwise one could write $\Sigma_0 = (\Sigma_0 \cap A^+) \cup (\Sigma_0 \cap A^-)$, a union of two relatively closed disjoint sets, a contradiction. But now it is clear that, Γ being polygonal, it can easily be retracted to a point in A^- , proving the claim. \square

7 Dual formulation and classification of blow-up limits

Blow-up limits are not easy to handle in the original formulation of the problem because it is of min-max type, so that the functional is not easily localizable. To overcome this difficulty we use a dual formulation of the problem to transform the min-max into a min-min, and then in many aspects we follow the strategy pursued by Bonnet [3] for Mumford-Shah minimizers.

More precisely, we prove, using a duality argument, that the blow-up limits converges to the following type of global minimizers, that we call *compliance global minimizer* in analogy with the Mumford-Shah problem.

Definition 7.1. *A (compliance) global minimizer in \mathbb{R}^2 is a pair (u, Σ) with $\Sigma \subset \mathbb{R}^2$ closed, and $u \in H_{0,\Sigma,loc}^1(\mathbb{R}^2)$ such that for every ball $B \subset \mathbb{R}^2$ we have*

$$\frac{1}{2} \int_B |\nabla u|^2 dx + \mathcal{H}^1(\Sigma \cap B) \leq \frac{1}{2} \int_B |\sigma|^2 dx + \mathcal{H}^1(\Sigma' \cap B),$$

for all vector fields $\sigma \in L_{loc}^2(\mathbb{R}^2; \mathbb{R}^2)$ satisfying $\sigma = \nabla u$ in $\mathbb{R}^2 \setminus B$ and $\text{div} \sigma = 0$ in $\mathbb{R}^2 \setminus \Sigma'$, where Σ' is any closed set $\Sigma' \subset \mathbb{R}^2$ satisfying $\Sigma \cap B = \Sigma' \cap B$ and $\Sigma' \cap \overline{B}$ is connected.

Assuming furthermore that Σ is connected (which actually occurs in our case), our notion of global minimizer (u, Σ) turns out to be exactly the dual one of Mumford-Shah global minimizers, thus Σ must be of the same type of the ones from the Mumford-Shah functional.

7.1 Dual formulation

We introduce the following dual formulation of our problem.

Proposition 7.2. *Let $f \in L^2(\Omega)$. Then Problem 1.1 is equivalent to the minimization problem*

$$\min_{(\sigma, \Sigma) \in \mathcal{B}} \frac{1}{2} \int_{\Omega} |\sigma|^2 dx + \mathcal{H}^1(\Sigma) \tag{92}$$

where

$$\mathcal{B} := \{(\sigma, \Sigma) : \Sigma \subset \overline{\Omega} \text{ compact connected and } \sigma \in L^2(\Omega; \mathbb{R}^2) \text{ satisfies } \text{div} \sigma = f \text{ in } \mathcal{D}'(\Omega \setminus \Sigma)\}$$

in the sense that the minimum value of the latter is equal to that of the original Problem 1.1, and once $(\sigma, \Sigma) \in \mathcal{B}$ is a minimizer for (92), then Σ solves the original Problem 1.1.

In addition, for a given compact connected $\Sigma \subset \overline{\Omega}$ fixed, the choice $\sigma := \nabla u_{\Sigma}$ solves

$$\min \left\{ \frac{1}{2} \int_{\Omega} |\sigma|^2 dx : \text{div} \sigma = f \text{ in } \mathcal{D}'(\Omega \setminus \Sigma) \right\}.$$

Proof. For any given $u \in H_0^1(\Omega \setminus \Sigma)$ and $\sigma \in L^2(\Omega; \mathbb{R}^2)$, we can write

$$\begin{aligned} \int_{\Omega} |\nabla u|^2 dx &= \int_{\Omega} |\nabla u - \sigma|^2 dx + 2 \int_{\Omega} \nabla u \cdot \sigma dx - \int_{\Omega} |\sigma|^2 dx \\ &\geq 2 \int_{\Omega} \nabla u \cdot \sigma dx - \int_{\Omega} |\sigma|^2 dx, \end{aligned}$$

and since we have equality for $\sigma = \nabla u$, we then have just proven the standard Legendre transform identity

$$\int_{\Omega} |\nabla u|^2 dx = \max_{\sigma \in L^2(\Omega; \mathbb{R}^2)} \left(2 \int_{\Omega} \nabla u \cdot \sigma dx - \int_{\Omega} |\sigma|^2 dx \right). \quad (93)$$

Therefore,

$$\begin{aligned} -\mathcal{C}(\Sigma) &= \min_{u \in H_0^1(\Omega \setminus \Sigma)} \left(\max_{\sigma \in L^2(\Omega; \mathbb{R}^2)} \left(\int_{\Omega} \nabla u \cdot \sigma dx - \frac{1}{2} \int_{\Omega} |\sigma|^2 dx \right) - \int_{\Omega} u f dx \right) \\ &= \min_{u \in H_0^1(\Omega \setminus \Sigma)} \max_{\sigma \in L^2(\Omega; \mathbb{R}^2)} F(u, \sigma), \quad \text{where} \\ F(u, \sigma) &:= \int_{\Omega} \nabla u \cdot \sigma dx - \frac{1}{2} \int_{\Omega} |\sigma|^2 dx - \int_{\Omega} u f dx. \end{aligned}$$

Now we want to exchange min and max in the above formula. Although it follows from quite standard results of convex analysis, in this particular setting the proof is elementary: it is clear that we always have

$$\min_{u \in H_0^1(\Omega \setminus \Sigma)} \max_{\sigma \in L^2(\Omega; \mathbb{R}^2)} F(u, \sigma) \geq \sup_{\sigma \in L^2(\Omega; \mathbb{R}^2)} \inf_{u \in H_0^1(\Omega \setminus \Sigma)} F(u, \sigma) = \sup_{\sigma \in D} \left(-\frac{1}{2} \int_{\Omega} |\sigma|^2 dx \right),$$

where D stands for the space of $\sigma \in L^2(\Omega; \mathbb{R}^2)$ such that

$$\int_{\Omega} \sigma \cdot \nabla \varphi dx = \int_{\Omega} f \varphi dx \quad \text{for all } \varphi \in H_0^1(\Omega \setminus \Sigma), \quad (94)$$

otherwise the infimum in u would be $-\infty$.

To verify the reverse inequality, we consider the minimizer u_{Σ} for the problem

$$\min_{u \in H_0^1(\Omega \setminus \Sigma)} \frac{1}{2} \int_{\Omega} |\nabla u|^2 dx - \int_{\Omega} u f dx.$$

We observe that the optimality conditions on u_{Σ} yields $\nabla u_{\Sigma} \in D$. Thus, recalling that the maximum in (93) is attained at $\sigma := \nabla u$ for $u \in H_0^1(\Omega \setminus \Sigma)$, we get

$$\begin{aligned} \min_{u \in H_0^1(\Omega \setminus \Sigma)} \max_{\sigma \in L^2(\Omega; \mathbb{R}^2)} F(u, \sigma) &= \min_{u \in H_0^1(\Omega \setminus \Sigma)} \left(\frac{1}{2} \int_{\Omega} |\nabla u|^2 dx - \int_{\Omega} u f dx \right) \\ &= -\frac{1}{2} \int_{\Omega} |\nabla u_{\Sigma}|^2 dx \leq \sup_{\sigma \in D} \left(-\frac{1}{2} \int_{\Omega} |\sigma|^2 dx \right). \end{aligned}$$

In conclusion, we have proven that

$$-\frac{1}{2} \int_{\Omega} |\nabla u_{\Sigma}|^2 dx = \min_{u \in H_0^1(\Omega \setminus \Sigma)} \left(\frac{1}{2} \int_{\Omega} |\nabla u|^2 dx - \int_{\Omega} u f dx \right) = \max_{\sigma \in D} \left(-\frac{1}{2} \int_{\Omega} |\sigma|^2 dx \right),$$

and $\sigma = \nabla u_{\Sigma}$ is a maximizer. It follows that

$$\min_{\Sigma} \frac{1}{2} \int_{\Omega} |\nabla u_{\Sigma}|^2 + \mathcal{H}^1(\Sigma) = \min_{\sigma \in \mathcal{D}, \Sigma \in \mathcal{K}(\Omega)} \frac{1}{2} \int_{\Omega} |\sigma|^2 + \mathcal{H}^1(\Sigma),$$

and the proposition follows from the uniqueness of u_{Σ} and the minimizer σ . \square

Remark 7.3. The dual formulation yields another proof for the Ahlfors regularity of minimizers. Indeed, if $B := B_r(x)$, $x \in \Sigma$, recalling that $(\nabla u_\Sigma, \Sigma)$ is a minimizer for the Problem (92), we can consider the competitor (σ', Σ') defined by

$$\begin{aligned} \Sigma' &:= (\Sigma \setminus B) \cup (\partial B \cap \Omega), \\ \sigma' &:= \begin{cases} \nabla u_\Sigma & \text{in } \Omega \setminus B, \\ \nabla u & \text{in } B \cap \Omega, \text{ where } u \in H_0^1(B) \text{ solves } -\Delta u = f. \end{cases} \end{aligned}$$

Then

$$\frac{1}{2} \int_{B \cap \Omega} |\nabla u_\Sigma|^2 dx + \mathcal{H}^1(\Sigma \cap B) \leq 2\pi r + \frac{1}{2} \int_{B \cap \Omega} |\nabla u|^2 dx, \quad (95)$$

and it remains to estimate $\int_B |\nabla u|^2 dx$. For this we observe that for every $\varphi \in H_0^1(B \cap \Omega)$ one has

$$\int_{B \cap \Omega} \nabla u \cdot \nabla \varphi dx = \int_{B \cap \Omega} \varphi f dx,$$

so that taking $\varphi := u$ and using the Poincaré inequality we obtain

$$\int_{B \cap \Omega} |\nabla u|^2 dx = \int_{B \cap \Omega} u f dx \leq \|u\|_{L^2(B)} \|f\|_{L^2(B \cap \Omega)} \leq Cr \|\nabla u\|_{L^2(B \cap \Omega)} \|f\|_2,$$

and thus

$$\int_{B \cap \Omega} |\nabla u|^2 dx \leq Cr^2 \|f\|_2,$$

where $C > 0$ is a universal constant. We conclude then from (95) the estimate

$$\mathcal{H}^1(\Sigma \cap B) \leq \frac{1}{2} \int_{B \cap \Omega} |\nabla u_\Sigma|^2 dx + \mathcal{H}^1(\Sigma \cap B) \leq 2\pi r + Cr^2 \|f\|_2^2, \quad (96)$$

which in particular implies the Ahlfors regularity of Σ .

7.2 Minimization problem for the blow-up limit

The aim of this section is to prove the following assertion.

Proposition 7.4. *The limit (u_0, Σ_0) of Proposition 6.1 is a compliance global minimizer in the sense of Definition 7.1. In addition, for any ball $B \subset \mathbb{R}^2$ one has that*

$$\mathcal{H}^1(\Sigma_{n_k} \cap B) \rightarrow \mathcal{H}^1(\Sigma_0 \cap B), \quad (97)$$

where Σ_{n_k} is as in Proposition 6.1.

Proof. Let Σ_{n_k} , u_{n_k} , f_n , Σ_0 and u_0 be as in Proposition 6.1, and we further write n instead of n_k for brevity. We will use the dual formulation (92) which says that for all $n \in \mathbb{N}$, the pair $(\nabla u_n, \Sigma_n)$ solves

$$\begin{aligned} \min_{(\sigma, \Sigma) \in \mathcal{B}_n} \frac{1}{2} \int_{\Omega_n} |\sigma|^2 dx + \mathcal{H}^1(\Sigma), \quad \text{where} \\ \mathcal{B}_n := \{(\sigma, \Sigma) : \Sigma \in \mathcal{K}(\Omega_n) \text{ and } \sigma \in L^2(\Omega_n, \mathbb{R}^2) \text{ satisfies } \operatorname{div} \sigma = f_n \text{ in } \mathcal{D}'(\Omega_n \setminus \Sigma)\}. \end{aligned} \quad (98)$$

Now let $B \subset \mathbb{R}^2$ be a ball. We may assume without loss of generality that $B = B_1(0)$. All the balls in this proof will by default be centered at the origin. Let the pair (σ, Σ') be a competitor to (u_0, Σ_0) in B in the sense of Definition 7.1, i.e. satisfying $\Sigma' \setminus B = \Sigma_0 \setminus B$ and $\Sigma' \cap \overline{B}$ is connected.

Let $\varepsilon \in (0, 1)$ be a small parameter. We can choose an $s \in (1, 1 + \varepsilon)$ such that

$$N := \#\Sigma_0 \cap \partial B_s < +\infty$$

(notice that Σ_0 has finite length due to Gołab's theorem and the Ahlfors regularity of Σ_n with same constant). Let $\delta > 0$ be another small parameter, and let us define the set

$$S_\delta := \{x \in \partial B_s : \text{dist}(x, \Sigma_0) \leq \delta\}.$$

Then since Σ_n converges to Σ_0 in the Kuratowski sense in \mathbb{R}^2 , it follows that for n large enough, $\Sigma_n \cap B_2$ stays inside a δ -neighborhood of $\Sigma_0 \cap B_2$, thus it is easily seen that the set

$$\Sigma'_n := (\Sigma_n \setminus B) \cup (\Sigma' \cap B_s) \cup S_\delta$$

is arcwise connected.

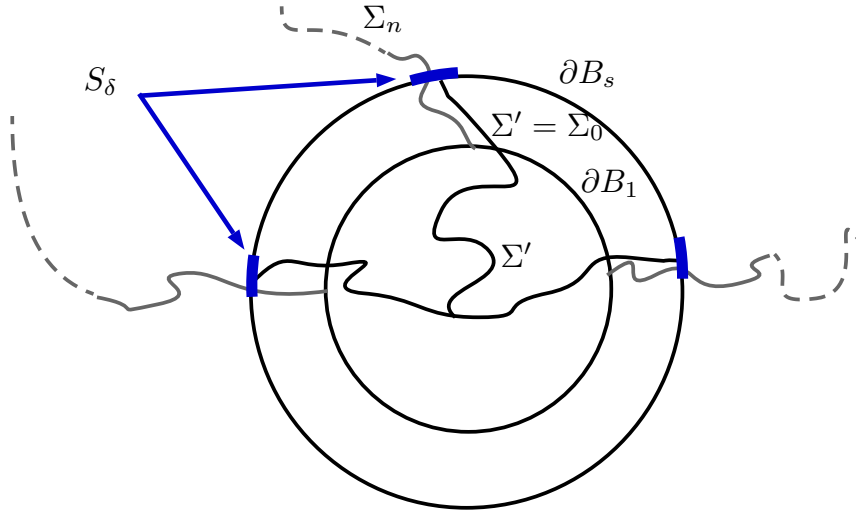

Figure 7.1: Construction of the competitor Σ'_n in Proposition 7.4.

Let now $\sigma \in L^2_{loc}(\mathbb{R}^2; \mathbb{R}^2)$ be as above, a competing vector field associated to Σ' in the sense of Definition 7.1, i.e. $\sigma = \nabla u_0$ in $\mathbb{R}^2 \setminus B$ and $\text{div} \sigma = 0$ in $\mathbb{R}^2 \setminus \Sigma'$. We want to prove that

$$\frac{1}{2} \int_B |\nabla u_0|^2 dx + \mathcal{H}^1(\Sigma_0 \cap B) \leq \frac{1}{2} \int_B |\sigma|^2 dx + \mathcal{H}^1(\Sigma' \cap B). \quad (99)$$

For this purpose we modify σ to make it admissible as a competitor for the minimization problem (98), i.e. construct a vector field $\tilde{\sigma}_n$ such that $(\tilde{\sigma}_n, \Sigma'_n) \in \mathcal{B}_n$. We start by considering a $2/(s-1)$ -Lipschitz cut-off function φ equal to 1 on B_1 and to 0 outside $B_{1+(s-1)/2}$, and we let

$$\sigma_n := \varphi \sigma + (1 - \varphi) \nabla u_n.$$

Notice that

$$\text{div} \sigma_n = (\sigma - \nabla u_n) \cdot \nabla \varphi + (1 - \varphi) f_n =: g_n \quad \text{in } \mathcal{D}'(\Omega_n \setminus \Sigma'_n),$$

and that

$$g_n \rightarrow 0 \text{ strongly in } L^2_{loc}(\mathbb{R}^2),$$

because $\sigma = \nabla u_0$ a.e. in $\mathbb{R}^2 \setminus B$, $\nabla u_n \rightarrow \nabla u_0$ strongly in $L^2_{loc}(\mathbb{R}^2; \mathbb{R}^2)$ and $f_n \rightarrow 0$ strongly in $L^2_{loc}(\mathbb{R}^2)$ (recall that u_0 is harmonic by Proposition 6.1). We now add a correction because we would like the divergence to be exactly equal to f_n . For this purpose we denote, for convenience, $r_0 := 1 + \varepsilon$ and let v_n be the solution for the problem

$$\min_{v \in H^1_{0, \Sigma'_n}(B_{r_0} \setminus \Sigma'_n)} \int_{B_{r_0}} |\nabla v|^2 dx - 2 \int_{B_{r_0}} (f_n - g_n) v dx.$$

In other words we are solving the problem $-\Delta v_n = f_n - g_n$ in $B_{r_0} \setminus \Sigma'_n$, $v_n = 0$ on $\Sigma'_n \cap B_{r_0}$ and $\nabla v_n \cdot \nu = 0$ on $\partial B_{r_0} \setminus \Sigma'_n$. It follows that

$$-\operatorname{div}(\mathbf{1}_{B_{r_0}} \nabla v_n) = (f_n - g_n) \mathbf{1}_{B_{r_0}} \text{ in } \mathcal{D}'(\mathbb{R}^2 \setminus \Sigma'_n).$$

In addition one has the estimate

$$\int_{B_{r_0}} |\nabla v_n|^2 dx = \int_{B_{r_0}} (f_n - g_n) v_n dx \leq \|f_n - g_n\|_{L^2(B_{r_0})} \|v_n\|_{L^2(B_{r_0})}. \quad (100)$$

Since v_n vanishes on the substantially large piece of set $\Sigma_0 \cap B_{1+\varepsilon} \setminus B_1$, by Poincaré inequality (Lemma A.2) we infer that

$$\int_{B_{r_0}} |v_n|^2 dx \leq C(\varepsilon) \int_{B_{r_0}} |\nabla v_n|^2 dx,$$

thus (100) gives

$$\int_{B_{r_0}} |\nabla v_n|^2 dx \leq C(\varepsilon) \|f_n - g_n\|_{L^2(B_{r_0})}^2 \rightarrow 0. \quad (101)$$

Consider now the function

$$\tilde{\sigma}_n := \sigma_n - \mathbf{1}_{B_{r_0}} \nabla v_n,$$

which, by construction, satisfies

$$\operatorname{div} \tilde{\sigma}_n = f_n \text{ in } \Omega_n \setminus \Sigma'_n,$$

i.e. $(\tilde{\sigma}_n, \Sigma'_n) \in \mathcal{B}_n$. Since $(\nabla u_n, \Sigma_n)$ is a minimizer for the problem (98), it follows that

$$\int_{\Omega_n} |\nabla u_n|^2 dx + \mathcal{H}^1(\Sigma_n) \leq \int_{\Omega_n} |\tilde{\sigma}_n|^2 dx + \mathcal{H}^1(\Sigma'_n).$$

Since both $\tilde{\sigma}_n = \nabla u_n$ and $\Sigma'_n = \Sigma_n$ outside B_{r_0} , we get

$$\begin{aligned} \int_{B_{r_0}} |\nabla u_n|^2 dx + \mathcal{H}^1(\Sigma_n \cap B_{r_0}) &\leq \int_{B_{r_0}} |\tilde{\sigma}_n|^2 dx + \mathcal{H}^1(\Sigma'_n \cap B_{r_0}) \\ &\leq \int_{B_{r_0}} |\tilde{\sigma}_n|^2 dx + \mathcal{H}^1(\Sigma' \cap B_{r_0}) + \mathcal{H}^1(\Sigma_n \cap B_{r_0} \setminus B_1) + cN\delta, \end{aligned}$$

where we have estimated $\mathcal{H}^1(S_\delta) \leq cN\delta$, with $c > 0$ being a universal constant. In other words,

$$\int_{B_{r_0}} |\nabla u_n|^2 dx + \mathcal{H}^1(\Sigma_n \cap B_1) \leq \int_{B_{r_0}} |\tilde{\sigma}_n|^2 dx + \mathcal{H}^1(\Sigma' \cap B_{r_0}) + cN\delta. \quad (102)$$

Notice that

$$\mathcal{H}^1(\Sigma_0 \cap B) \leq \liminf_n \mathcal{H}^1(\Sigma_n \cap B), \quad (103)$$

thanks to Golab's Theorem (one can just use the classical Golab theorem applied to the sequence of compact connected sets $(\Sigma_n \cap B) \cup \partial B$ which converges to $(\Sigma \cap B) \cup \partial B$ in the Hausdorff distance by Proposition 6.1 (i)).

Taking the liminf in n of (102), using the fact that $\tilde{\sigma}_n \rightarrow \sigma$ strongly in $L^2(B_{r_0}; \mathbb{R}^2)$ we obtain that

$$\int_{B_{r_0}} |\nabla u_0|^2 dx + \mathcal{H}^1(\Sigma_0 \cap B_{r_0}) \leq \int_{B_{r_0}} |\sigma|^2 dx + \mathcal{H}^1(\Sigma' \cap B_{r_0}) + cN\delta.$$

We can now let $\delta \rightarrow 0^+$ and then $\varepsilon \rightarrow 0^+$ to get

$$\int_{B_1} |\nabla u_0|^2 dx + \mathcal{H}^1(\Sigma_0 \cap B_1) \leq \int_{B_1} |\sigma|^2 dx + \mathcal{H}^1(\Sigma' \cap B_1),$$

which concludes the proof of the fact that (u_0, Σ_0) is a global minimizer.

It remains to prove that

$$\mathcal{H}^1(\Sigma_n \cap B) \rightarrow \mathcal{H}^1(\Sigma \cap B).$$

Inequality (103) gives the first half. To prove the reverse inequality, we pass to the limsup in n in (102) with the special choice $\Sigma' = \Sigma_0$ and $\sigma = \nabla u_0$. Using $\nabla u_n \rightarrow \nabla u_0$ we obtain

$$\limsup_n \mathcal{H}^1(\Sigma_n \cap B) \leq \mathcal{H}^1(\Sigma_0 \cap B) + cN\delta$$

and letting $\delta \rightarrow 0^+$ we conclude the proof. \square

7.3 Another formulation and characterization of global minimizers

In this section we give another formulation of global minimizers and prove that it is equivalent to Mumford-Shah minimizers.

Definition 7.5. A pair (u, K) with $K \subset \mathbb{R}^2$ closed is called *global Mumford-Shah minimizer*, if $u \in L^2_{loc}(\mathbb{R}^2 \setminus K)$ and $\nabla u \in L^2_{loc}(\mathbb{R}^2)$ satisfies

$$\int_B |\nabla u|^2 dx + \mathcal{H}^1(K \cap B) \leq \int_B |\nabla v|^2 dx + \mathcal{H}^1(L \cap B),$$

for every ball $B \subset \mathbb{R}^2$ and for all (v, L) satisfying $v = u$ in $\mathbb{R}^2 \setminus B$ and $K \setminus B = L \setminus B$, and such that $L \cap \bar{B}$ is connected.

Remark 7.6. The original definition of Bonnet [3] was slightly different, with a less restrictive topological condition of competitors, namely keeping $\{x, y\} \subset \mathbb{R}^2 \setminus B$ separated by L as soon as they were separated by K . We cannot use here exactly the same definition of competitors because we need our competitors to be connected. However, our definition is stronger, in the sense that any of our compliance global minimizers is automatically a global minimizer in the sense of Bonnet, which is enough to get the classification of global minimizers.

Definition 7.7. If $\Omega \subset \mathbb{R}^2$ is open and u is harmonic in Ω , we call *harmonic conjugate* for u in Ω a harmonic function v in Ω such that $\nabla v = \nabla^T u$, where the notation $\nabla^T u$ is used for the vector field $(-\partial_y u, \partial_x u)$.

Proposition 7.8. Let (u_0, Σ_0) be a global minimizer in the sense of Definition 7.1. Assume moreover that every connected component of $\mathbb{R}^2 \setminus \Sigma_0$ is simply connected. Then, u_0 admits a harmonic conjugate u in $\mathbb{R}^2 \setminus \Sigma_0$, and (u, Σ_0) is a Mumford-Shah global minimizer in the sense of Definition 7.5.

Proof. Since each component of $\mathbb{R}^2 \setminus \Sigma_0$ is simply connected, u_0 admits a harmonic conjugate. Namely, for any $U \subset \mathbb{R}^2 \setminus \Sigma_0$ connected component, since $\operatorname{div} \nabla u_0 = 0$ in $\mathcal{D}'(U)$, by De Rham's theorem we get the existence of u harmonic in U such that $\nabla^T u_0 = \nabla u$ in $\mathbb{R}^2 \setminus \Sigma_0$. In particular, $\|\nabla u_0\|_{L^2(K)} = \|\nabla u\|_{L^2(K)}$ for all $K \subset \mathbb{R}^2$, compact.

Now let (v, Σ') be a competitor in some ball $B \subset \mathbb{R}^2$, i.e. $v = u$ in $B \setminus \mathbb{R}^2$, $\Sigma' \setminus B = \Sigma_0 \setminus B$ and $\Sigma' \cap \overline{B}$ is connected. Then we define $\sigma := \nabla^T v$. In particular, $\operatorname{div} \sigma = 0$ in $\mathbb{R}^2 \setminus \Sigma'$ and $\sigma = \nabla^T u = \nabla u_0$ in $\mathbb{R}^2 \setminus B$. By the minimality of (u_0, Σ_0) in the sense of Definition 7.1 we have

$$\int_B |\nabla u_0|^2 dx + \mathcal{H}^1(\Sigma_0 \cap B) \leq \int_B |\sigma|^2 dx + \mathcal{H}^1(\Sigma' \cap B),$$

which implies

$$\int_B |\nabla u|^2 dx + \mathcal{H}^1(\Sigma_0 \cap B) \leq \int_B |\nabla v|^2 dx + \mathcal{H}^1(\Sigma' \cap B),$$

thus (u, Σ_0) is a global Mumford-Shah minimizer. \square

As a direct consequence we get the following.

Proposition 7.9. *Any blow-up limit (u_0, Σ_0) given by Proposition 6.1 is one of the following list, up to a translation, rotation, dilatation, or adding a constant for u_0 :*

- (i) Σ_0 is a line and u_0 is a constant on each side of it;
- (ii) Σ_0 is a propeller (three half lines meeting in a single point by number of 3 at 120 degree angles) and u_0 is a constant in each of the sectors formed by these half lines;
- (iii) Σ_0 is a half-line and u_0 is the “Dirichlet-craktip” function $(r, \theta) \mapsto \sqrt{r/2\pi} \cos(\theta/2)$ written in polar coordinates $(r, \theta) \in [0, +\infty) \times (-\pi, \pi)$.

Proof. Proposition 6.10, Proposition 7.4 and Proposition 7.8 imply that Σ_0 is a global Mumford-Shah minimizer in the sense of Definition 7.5. To obtain that Σ_0 is the singular set of a global Mumford-Shah minimizer in the sense of Bonnet, it is enough to prove that it satisfies the topological condition of Bonnet, namely, that each pair of points x and y in $\Sigma_0 \setminus B$ that are separated by Σ_0 , are still separated by any competitor L . But this is clear due to the fact that $L \cap \overline{B}$ is connected. It follows from Bonnet [3] that it must be one of the list described above (notice that the blow-up limit is never empty since we blow-up a connected set). \square

7.4 Blow-up limit at a boundary point

The purpose of this section is to state results analogous to those of the previous sections, in the particular case of a boundary point, namely when $x_n \rightarrow x_0 \in \partial\Omega$. Since the proofs are very similar, we will only highlight the main differences. Later we will put together the results in a single statement. We first define the type of minimizing problem that arises at the limit.

Definition 7.10. *Let $H \subset \mathbb{R}^2$ be a closed half-plane. Then, a closed and arcwise connected set $\Sigma \subset H$ is a boundary compliance global minimizer in H if it satisfies the following minimizing property: for every open ball $B \subset \mathbb{R}^2$ and every competitor $L \subset H$, satisfying $L \setminus B = \Sigma \setminus B$ and such that $L \cap \overline{B}$ is connected, one has*

$$\mathcal{H}^1(\Sigma \cap B) \leq \mathcal{H}^1(L \cap B). \quad (104)$$

Remark 7.11. A direct consequence of (104) is that Σ has locally finite Hausdorff measure (take $(\Sigma \setminus B) \cup \partial(B \cup H)$ as a competitor).

Remark 7.12. Our class of boundary compliance global minimizers looks similar to the one dimensional sliding minimal sets studied in [12, 15]. Notice however that our class is quite different (and, actually, is simpler) because we do not impose any sliding condition: in our situation, the competitors are not obliged to preserve the points of $\Sigma \cap \partial H$ on the boundary, they are free to be detached and move everywhere including inside the domain. We indeed will arrive at a different classification than the one of [15, Lemma 4.3].

Theorem 7.13. *Assume that $f \in L^p(\Omega)$, $p > 2$, where Ω is a C^1 domain. Let (u_n, Σ_n) be the blow-up sequence in Ω_n defined in (66) and (67) with $x_n \rightarrow x_0 \in \partial\Omega$ and assume that $d(x_{n_k}, \partial\Omega) \leq r_{n_k}$ for a subsequence (otherwise the blow-up analysis is exactly the same as the interior case). Then there exists a further subsequence (still indexed by n_k) such that Ω_{n_k} converges to a half-plane and*

- (i) $\Sigma_{n_k} \rightarrow \Sigma_0$ in the Kuratowski sense in \mathbb{R}^2 ,
- (ii) $u_{n_k} \rightarrow 0$ strongly in $H_{loc}^1(\mathbb{R}^2)$,
- (iii) Σ_0 is a boundary compliance global minimizer in the sense of Definition 7.10,
- (iv) $\mathcal{H}^1(\Sigma_{n_k} \cap B) \rightarrow \mathcal{H}^1(\Sigma_0 \cap B)$ for every ball B .

Proof. Let us index the sequence by n instead of n_k . The proof is the same as in the case of interior points. The only difference is that now Ω_n blows-up to a half-plane instead of the whole \mathbb{R}^2 . Indeed, the assumption $d(x_n, \partial\Omega) \leq r_n$ says that for all n , there exists some $z_n \in \partial\Omega$ with $d(z_n, x_n) \leq r_n$ and in particular $d(z_n, x_0) \rightarrow 0$. Since $\partial\Omega$ is C^1 , it is clear that the blow-up of Ω at z_n is the tangent line of $\partial\Omega$ at this point, and converges to the tangent line at point x_0 . Comparing the blow-up at z_n and the one at x_n (for instance by noticing $B_{r_n}(z_n) \subset B_{2r_n}(x_n) \subset B_{4r_n}(z_n)$), we deduce that Ω_n blows up to a half-plane.

Let us assume without loss of generality that this half-plane is

$$H = \{(x, y) \in \mathbb{R}^2 : x \leq 0\}.$$

The proofs of Proposition 6.1 and Proposition 6.10 can be followed line by line without any change even at the boundary, leading to the fact that $\Sigma_n \rightarrow \Sigma_0$ in the Kuratowski sense in \mathbb{R}^2 , Σ_0 is arcwise connected and $\mathbb{R}^2 \setminus \Sigma_0$ is simply connected, and finally u_n converges strongly in $H_{loc}^1(\mathbb{R}^2)$ to a harmonic function u_0 in $H \setminus \Sigma_0$.

We prove now that $\nabla u_0 = 0$. Indeed, Lemma 3.5 implies

$$\int_{B_r(z_n)} |\nabla u_\Sigma|^2 dx \leq C_1 \left(\frac{r}{r_0} \right)^{1+\delta},$$

for some $\delta > 0$, $r_0 > 0$, and all $r \in (0, r_0)$, where C_1 depends only on $|\Omega|$, p , $\|f\|_p$. This estimate, since $B_{r_n}(z_n)$ and $B_{r_n}(x_n)$ are comparable in the sense that $B_{r_n}(z_n) \subset B_{2r_n}(x_n) \subset B_{4r_n}(z_n)$, implies

$$\frac{1}{r_n} \int_{B_{r_n}(x_n)} |\nabla u_\Sigma|^2 dx \xrightarrow{n \rightarrow +\infty} 0,$$

and this yields $\nabla u_0 = 0$ as claimed.

Now comes the identification of the minimization problem arising at the limit. For this purpose we follow the proof of Proposition 7.4. Everything works the same way except that now the competitor Σ'_n may not be admissible, since it may not be inside Ω . We then modify the proof as follows: by the C^1 regularity of $\partial\Omega$, we know that there exists some $\eta_n \rightarrow 0$ such that $\partial\Omega \cap B_{r_n}(z_n) \subset C_{\eta_n}$, where C_η is a cone of aperture η , namely

$$C_\eta := \{(x, y) \in \mathbb{R}^2 : |x| \leq \eta|y|\}.$$

For every η , let $\Phi_\eta : H \rightarrow H \setminus C_\eta$ be the following $(1 + \eta)$ -Lisphchitz mapping

$$\Phi_\eta(x, y) = (x - \eta|y|, y).$$

Let now Σ' be a competitor for Σ_0 in some ball $B \subset \mathbb{R}^2$. Then $\Sigma'' := \Phi_{\eta_n}(\Sigma_0) \subset \Omega_n$ and

$$\mathcal{H}^1(\Sigma'') \leq (1 + \eta_n)\mathcal{H}^1(\Sigma').$$

The rest of the proof then follows the same way with Σ'' in place of Σ' . \square

Proposition 7.14. *Let Σ be a boundary compliance global minimizer in the sense of Definition 7.10 with $\Sigma \cap \partial H \neq \emptyset$. Then $\Sigma = \partial H$.*

Proof. Let $x_0 \in \Sigma \cap \partial H$, S be a connected component of $\Sigma \cap \overline{B}_R$ containing x_0 and $N := S \cap \partial B_R$, where $R > 0$ is arbitrary, the balls here and below being centered at x_0 . Then one has, in the notation of Lemma 7.15, that $S \in \mathcal{St}(N)$, since otherwise for an arbitrary $K \subset \mathcal{St}(N)$ taking $L := (\Sigma \setminus S) \cup \overline{K}$, one gets, recalling that $K \subset \overline{B}_R$ by Lemma 7.15 (see below), the estimate

$$\mathcal{H}^1(L \cap \overline{B}_R) = \mathcal{H}^1((\Sigma \setminus S) \cap \overline{B}_R) + \mathcal{H}^1(K) < \mathcal{H}^1((\Sigma \setminus S) \cap \overline{B}_R) + \mathcal{H}^1(S \cap \overline{B}_R) = \mathcal{H}^1(\Sigma \cap \overline{B}_R)$$

contradicting the assumption that Σ be a compliance global minimizer. But then by Lemma 7.15 the set S may not contain x_0 unless $\{A_R^+, A_R^-\} \subset N$, where $\{A_R^+, A_R^-\} := \partial B_R \cap \partial H$. In fact, if either of the points A_R^\pm does not belong to N , then x_0 does not belong to the closed convex envelope of N . This shows $\{A_R^+, A_R^-\} \subset N$, and hence, since $R > 0$ is arbitrary, then $\partial H \subset \Sigma$.

To show that in fact $\Sigma = \partial H$, we assume the contrary, and let now $R > 0$ be such that $\#(\Sigma \cap \partial B_R)$ is finite (by coarea inequality, a.e. $R > 0$ would suit for this purpose because Σ has locally finite length) and a connected component S of $\Sigma \cap B_R$ containing the line segment $l := \partial H \cap B_R$ does not coincide with the latter. Then this component belongs to $\mathcal{St}(N' \cup \bar{l})$, with $N' \subset \Sigma \cap \partial B_R$ and hence by [29, Theorem 7.4] is a finite embedded graph consisting of line segments with exactly one endpoint (we denote it by A) over \bar{l} . But this cannot happen since $S \in \mathcal{St}(N)$, where $N := S \cap \partial B_R$; in fact, then there is a line segment $(AB) \in S$ such that the angle between (AB) and \bar{l} is less than 120 degrees, which is impossible for Steiner sets connecting a finite number of points. This contradiction shows that the connected component of $\Sigma \cap B_R$ containing l must be l itself.

Finally it is easy to see that there exist no other connected components of $\Sigma \cap B_R(x_0)$ different from $l \cap B_R(x_0)$. Indeed, assuming the contrary, and letting x be a point belonging to the other component, using that Σ is arcwise connected, one can find a curve in Σ connecting x to x_0 . This curve has to branch on ∂H at some point y_0 . Then reasoning as before with a ball centered at y_0 instead of x_0 , we get a contradiction that concludes the proof. \square

Lemma 7.15. *For every $N \subset \mathbb{R}^n$ denote by $\mathcal{St}(N)$ the set of minimizers of the Steiner problem*

$$\min\{\mathcal{H}^1(K) : K \subset \mathbb{R}^n, K \cup N \text{ connected}\}.$$

Then for every $K \in \mathcal{St}(N)$ of finite length one has that \overline{K} belongs to the closed convex envelope of N .

Proof. If \overline{K} does not belong to the closed convex envelope of N , then its projection to the latter still connects N and has strictly lower length, contradicting the optimality of K . \square

Remark 7.16. A standard strategy to prove Proposition 7.14 would be to follow the usual classification of minimal cones. We used here a different and more elementary approach based on Lemma 7.15, but for the sake of completeness we describe the standard one: it is not difficult to see that if Σ is a cone centered at some point $x_0 \in \partial H$, then Σ can only be a half-line or a line

(the latter being true only if $\Sigma = \partial H$). It is not difficult to exclude the half-line by a competitor which would cut the “corner” near x_0 , showing that the only minimal cone is ∂H . Next, for an arbitrary compliance global minimizer Σ and $x_0 \in \partial H \cap \Sigma$, comparing as usual Σ with a cone over its trace on the boundary of a sphere, one shows that the density $\mathcal{H}^1(\Sigma \cap B_r)/r$ is monotone in r . Therefore the limiting densities at $r \rightarrow 0^+$ and $r \rightarrow +\infty$ do exist. Considering the blow-in and blow-up limits, due to the strong convergence of \mathcal{H}^1 along those sequences one can see that those limit densities can only be equal to two, because they are densities of a minimal cone. But then by monotonicity, the density of Σ itself is constant and equal to two so that Σ must be a line, leading to the conclusion $\Sigma = \partial H$.

Remark 7.17. Without any attempt to make it more precise here, one could also consider global minimizers in angular sectors instead of half-planes leading to some regularity issues in Lipschitz domains instead of C^1 domains. For instance, it is not difficult to see that in any convex angular sector, the only possible global minimizer is the empty set. This means, for instance, if Ω is a convex polygon, a minimizer Σ of Problem 1.1 will never touch a corner of $\partial\Omega$.

8 Conclusion and full regularity

In this section, we prove our main result on characterization of minimizers. In particular we are interested in the following statement.

Theorem 8.1. *Assume that $f \in L^p(\Omega)$, $p > 2$, where Ω is a C^1 domain. Then every minimizer Σ for Problem 1.1 consists of a finite number of embedded curves which are locally $C^{1,\alpha}$ inside Ω for some $\alpha \in (0, 1)$, meeting only by number of three at 120 degree angles. In particular, Σ has finite number of endpoints, finite number of branching points (which are all triple points where smooth curves meet at 120 degree angles), and at all the other points Σ is locally $C^{1,\alpha}$ -smooth.*

Remark 8.2. From the proof of Theorem 8.1 we deduce that for an arbitrary bounded open $\Omega \subset \mathbb{R}^2$, without any smoothness condition of the boundary, one has that the result analogous to Theorem 8.1 holds locally inside Ω , namely, for every $\Omega' \Subset \Omega$ and every minimizer Σ for Problem 1.1 one has that $\Sigma \cap \Omega'$ has finite number of branching points (which are all triple points where smooth curves meet at 120 degree angles), and at all the other points Σ is locally $C^{1,\alpha}$ -smooth for some $\alpha \in (0, 1)$.

Remark 8.3. If under conditions of Theorem 8.1 one has additionally that $\bar{\Omega}$ is convex, then every minimizer Σ for Problem 1.1 consists of a finite number of $C^{1,\alpha}$ embedded curves in $\bar{\Omega}$ for some $\alpha \in (0, 1)$, meeting only by number of three at 120 degree angles. The fact that the curves of Σ are $C^{1,\alpha}$ in $\bar{\Omega}$ comes from Proposition 5.19 which says that Σ is $C^{1,\alpha}$ locally around any “flat point” with low energy ω_Σ , and this holds true in $\bar{\Omega}$ provided that Ω is convex (Proposition 5.19). The conclusion then follows similarly to that of Theorem 8.1, in particular any point which is not an endpoint nor a triple point is a flat point and Lemma 3.5 (for the boundary case) or Proposition 6.2 (for the interior case) says that any “flat point” has low energy ω_Σ so that Proposition 5.19 applies.

The rest of the section is dedicated to the proof of the above Theorem 8.1.

8.1 Finite number of curves

To prove the assertion on the finite number of curves, we follow the approach of Bonnet [3] and start with the following observation.

Proposition 8.4. *Assume that $f \in L^p(\Omega)$, $p > 2$, where Ω is a C^1 domain, $\Sigma \subset \bar{\Omega}$ be a minimizer for the Problem 1.1 and let $x \in \Sigma$. Then all the possible blow-up limits at point x*

are of same type. The same result holds without any condition on the boundary of $\partial\Omega$, once $x \in \Sigma \cap \Omega$.

Proof. By Remark 3.4 we know that, for any $x \in \Sigma$ the limit

$$e(x) := \lim_{r \rightarrow 0^+} \frac{1}{r} \int_{B_r(x)} |\nabla u_\Sigma|^2 dx$$

exists, and is finite (due to (96)). By the strong convergence of the blow-ups of u_Σ in $H_{loc}^1(\mathbb{R}^2)$ to their limit, and recalling Proposition 7.9, we deduce that $e(x) = 0$ in the case when there exists a blow-up limit which is a line or a propeller, and $e(x) > 0$ only if all the blow-up limits are half-lines.

On the other hand, if a blow-up limit at point $x \in \Sigma \cap \Omega$ is a line, by local C^1 regularity Theorem 6.4 we know that all other blow-up limits must also be a line (and if $x \in \partial\Omega$ we also know that all blow-up sequences converge to the tangent lines to $\partial\Omega$). We then easily conclude that all the blow-up limits have same type: indeed, either $e(x) > 0$ and all blow-ups must be a half-line, or $e(x) = 0$. In the latter case, either there exists a blow-up which is a line, and then all other blow-ups must be also lines, or there is no lines and then all blow-ups are propellers. \square

Proposition 8.4 motivates the following terminology.

Definition 8.5. We define the type of $x \in \Sigma$ as follows.

- (i) x is called a regular point if all blow-up limits at point x are lines.
- (ii) x is called a triple point if all blow-up limits at point x are propellers.
- (iii) x is called an endpoint if all blow-up limits at point x are half-lines.

The proof of Theorem 8.1 now directly follows from Theorem 6.4 together with the following result.

Theorem 8.6. Assume that $f \in L^p(\Omega)$, $p > 2$, where Ω is a C^1 domain, and Σ be a minimizer for the Problem 1.1. Then the set of triple points and endpoints is a finite set.

Remark 8.7. The proof of Theorem 8.6 in the case of an arbitrary bounded open $\Omega \subset \mathbb{R}^2$ without any smoothness condition of the boundary gives that for every $\Omega' \Subset \Omega$ and every minimizer Σ for Problem 1.1 one has that $\Sigma \cap \Omega'$ has finite number of endpoints and finite number of branching points (which are all triple points where smooth curves meet at 120 degree angles).

Proof. We have now all the ingredients at hand to follow the same proof as [3, Theorem 5.1]. The proof is exactly the same as the one in [3] but we write full details here for the readers' convenience. It is enough to prove that the number of triple points is finite. Indeed, one may then consider $\Sigma \setminus \mathcal{T}$, where \mathcal{T} is the set of triple points. It has a finite number of connected components, each of them being a simple curve (without triple points), hence admitting exactly two endpoints; the endpoints of Σ are among endpoints of those connected components, hence they are finite in number.

The strategy to prove that the number of triple points is finite is to argue by contradiction. Assuming that there exists a sequence T_n of distinct triple points in Σ , we consider the blow-up limit

$$u_{\varepsilon_n}(x) = \varepsilon_n^{-\frac{1}{2}} u(T_n + \varepsilon_n R_n(x))$$

where R_n is the rotation that maps \mathbf{e}_1 on $T_n - T_{n+1}$ and $\varepsilon_n = |T_n - T_{n+1}|$. For this transformation, the rescaled set $\Sigma_{\varepsilon_n} := \{x \in \mathbb{R}^2 : T_n + \varepsilon_n R_n(x) \in \Sigma\}$ has at least two triple points, one at $(0, 0)$ and another one at $(1, 0)$. Along a subsequence (not relabelled), Σ_{ε_n} converges to some global

minimizer Σ_0 in the plane containing $(0, 0)$ and $(0, 1)$, and by the classification of blow-up limits, at least one of those two points is not a triple point for Σ_0 . Let us assume that $(0, 0)$ is not a triple point. Then it is a cracktip or a regular point, thus, thanks to Proposition 7.4 (for the case of points T_n converging to a point in Ω) or Theorem 7.13 (for the case of points T_n converging to a point in $\partial\Omega$), we get

$$\lim_n \mathcal{H}^1(\Sigma_{\varepsilon_n} \cap B_r) = \begin{cases} r, & \text{if } (0, 0) \text{ is a cracktip,} \\ 2r, & \text{if } (0, 0) \text{ is a regular point,} \end{cases} \quad (105)$$

and the convergence is uniform in $r \in (0, 1)$, because the functions $r \mapsto \mathcal{H}^1(\Sigma_{\varepsilon_n} \cap B_r)$ are all nondecreasing (the balls here and below are assumed to be centered in the origin).

Now, since by construction $(0, 0)$ is a triple point for Σ_{ε_n} , we also have, for any n fixed,

$$\lim_{r \rightarrow 0^+} \frac{\mathcal{H}^1(\Sigma_{\varepsilon_n} \cap B_r)}{r} = 3.$$

Let us define

$$\rho_n = \inf\{r > 0 : \mathcal{H}^1(\Sigma_{\varepsilon_n} \cap B_r) \leq 2.5r\}.$$

Because of (105), we deduce that $\rho_n \rightarrow 0$. Now let $\eta_n := \rho_n \varepsilon_n$ and let us consider the blow-up sequence $u_{\eta_n} = u(T_n + \eta_n R_n(x)) / \sqrt{\eta_n}$, $\Sigma_{\eta_n} = \{x \in \mathbb{R}^2 : T_n + \eta_n R_n(x) \in \Sigma\}$. By definition of ρ_n as an infimum we deduce that

$$2.5s \leq \mathcal{H}^1(\Sigma_{\varepsilon_n} \cap B_s) \quad \text{for all } s < \rho_n,$$

which implies, the estimate

$$\mathcal{H}^1(\Sigma_{\eta_n} \cap B_t) = \mathcal{H}^1(\Sigma_{\varepsilon_n} \cap B_{t\rho_n}) \frac{1}{\rho_n} \geq \frac{2.5t\rho_n}{\rho_n} = 2.5t \quad \text{for all } t < 1.$$

By taking $s_k := \rho_n^k$ a minimizing sequence for ρ_n , we also get

$$\mathcal{H}^1(\Sigma_{\varepsilon_n} \cap B_{\rho_n}) \leq \mathcal{H}^1(\Sigma_{\varepsilon_n} \cap B_{\rho_n^k}) \leq 2.5\rho_n^k,$$

which implies, passing to the limit as $k \rightarrow \infty$, the estimate

$$\mathcal{H}^1(\Sigma_{\varepsilon_n} \cap B_{\rho_n}) \leq 2.5\rho_n.$$

Therefore,

$$2.5t \leq \mathcal{H}^1(\Sigma_{\eta_n} \cap B_t) \leq \mathcal{H}^1(\Sigma_{\eta_n} \cap B_1) = \mathcal{H}^1(\Sigma_{\varepsilon_n} \cap B_{\rho_n}) / \rho_n \leq 2.5 \quad \text{for all } t < 1. \quad (106)$$

We have that Σ_{η_n} is another blow-up sequence for Σ , so that taking now a subsequence of Σ_{η_n} (not relabeled) converging to a global (resp. boundary global) minimizer Σ_0 , again by Proposition 7.4 (resp. Theorem 7.13) we get

$$\lim_n \mathcal{H}^1(\Sigma_{\eta_n} \cap B_t) = \mathcal{H}^1(\Sigma_0 \cap B_t)$$

for all $t \in [0, 1]$, and the latter quantity should be kt with $k \in \{1, 2, 3\}$ if the blow-up limit is done at an internal point (by Proposition 7.9) or $k = 2$, if the blow-up limit is done at a boundary point (by Proposition 7.14). This contradicts (106), thus concluding the proof. \square

8.2 Further regularity

In this section we derive some regularity of higher order. It relies on the classical elliptic regularity theory and the Euler-Lagrange equation associated to our problem.

Proposition 8.8. *Let Ω be an open set, $\lambda \in (0, \infty)$ and $f \in H^1(\Omega)$ (so that automatically $f \in L^p(\Omega)$ for any $p > 2$). Let Σ be a minimizer for Problem 1.1, and $x \in \Sigma \cap \Omega$, $r > 0$, $\alpha_0 \in (0, 1)$ such that $\gamma := \Sigma \cap B_r(x)$ is C^{1, α_0} . Then γ is $C^{2, \alpha}$ for any $\alpha \in (0, 1)$, and*

$$\left(\frac{\partial u^+}{\partial \nu}\right)^2 - \left(\frac{\partial u^-}{\partial \nu}\right)^2 + \lambda H_\gamma = 0 \quad \text{over } \gamma, \quad (107)$$

where u^+, u^- are the restrictions of u on the two connected components of $B_r(x) \setminus \gamma$ oriented in a suitable way, and H_γ denote the mean curvature.

If moreover f is $C^{k, \beta}$ in $B_r(x)$, for $k \in \mathbb{N}$ and $\beta \in (0, 1)$ then γ is $C^{k+3, \beta}$. And if f is furthermore analytic, then u and γ are analytic.

Proof. Equality (107) is proven in [5], where H_γ is understood in a weak sense. From [17, Theorem 8.34 and the remark at the end of section 8.11], u is $C^{2, \alpha}$ up to γ from each side, where $\alpha = 1 - \frac{n}{p}$. The regularity theory of the mean curvature equation gives the regularity of γ . The case $f \in C^{k, \alpha}$ and f analytic follows from a classical bootstrap argument (see also [20] for the case f analytic). \square

A Auxiliary results

We introduce the following notation. For a relatively open set $S \subset \partial B_r(0) \subset \mathbb{R}^n$, $\lambda_1(S)$ is the first eigenvalue of the Laplace-Beltrami operator over $H_0^1(S)$. For instance if $n = 2$ and S is an arc of a circumference, then it is easy to compute

$$\lambda_1(S) = \frac{\pi^2}{\mathcal{H}^1(S)^2}.$$

This gives a possibility to formulate the following immediate version of the Poincaré inequality.

Lemma A.1. *Let a function $u \in H^1(B_R(0)) \cap H_0^1(K^c)$ for some closed $K \subset \mathbb{R}^n$. Then for a.e. $r \in (0, R)$ such that $K \cap \partial B_r(0)$ has positive harmonic capacity in $\partial B_r(0)$, letting*

$$C := \sup \left\{ \frac{1}{\lambda_1(S)} : S \text{ connected component of } \partial B_r(0) \setminus K \right\},$$

one has

$$\int_{\partial B_r(0)} u^2 d\mathcal{H}^{n-1} \leq C \int_{\partial B_r(0)} |\nabla_\tau u|^2 d\mathcal{H}^{n-1}. \quad (108)$$

In particular, if $n = 2$ one has (108) for a.e. $r \in (0, R)$ such that $K \cap \partial B_r(0) \neq \emptyset$ with

$$C := \sup \left\{ \left(\frac{\mathcal{H}^1(S)}{\pi} \right)^2 : S \text{ connected component of } \partial B_r(0) \setminus K \right\}. \quad (109)$$

Proof. One has

$$\int_S u^2 d\mathcal{H}^{n-1} \leq \frac{1}{\lambda_1(S)} \int_S |\nabla_\tau u|^2 d\mathcal{H}^{n-1} \leq C \int_S |\nabla_\tau u|^2 d\mathcal{H}^{n-1} \quad (110)$$

for every connected component S of $\partial B_r(0) \setminus K$ so that summing (110) over all connected components of $\partial B_r(0) \setminus K$, we get (108). \square

A corollary is the following Poincaré inequality on the annulus.

Lemma A.2. *Let $\Sigma \subset \mathbb{R}^2$ be a closed connected set, $\Sigma \cap \overline{B}_r(x_0) \neq \emptyset$ and $\Sigma \setminus B_R(x_0) \neq \emptyset$. For a function $u \in H^1(B_R(x_0)) \cap H_0^1(\Sigma^c)$, one has*

$$\int_{B_R(x_0) \setminus B_r(x_0)} u^2 dx \leq 4R^2 \int_{(B_R(x_0) \setminus B_r(x_0)) \setminus \Sigma} |\nabla u|^2 dx \quad (111)$$

for every $r \in (0, R)$.

Proof. For every $\rho \in (r, R)$ one has $\Sigma \cap \partial B_\rho(x_0) \neq \emptyset$, and hence, by Lemma A.1, observing that in view of (109) the Poincaré constant over each sphere $\partial B_\rho(x_0)$ with $\rho \in (r, R)$ satisfies $C \leq 4\rho^2 \leq 4R^2$, we get

$$\int_{\partial B_\rho(x_0)} u^2 d\mathcal{H}^1 \leq 4R^2 \int_{\partial B_\rho(x_0) \setminus \Sigma} |\nabla_\tau u|^2 d\mathcal{H}^1 \leq 4R^2 \int_{\partial B_\rho(x_0) \setminus \Sigma} |\nabla u|^2 d\mathcal{H}^1.$$

Integrating the latter equation in $d\rho$ over $\rho \in (r, R)$, one gets (111). \square

We now prove the integration by parts formula.

Lemma A.3. *Let Σ be a closed set and $f \in L^2(\Omega)$. If $u \in H_0^1(\Omega \setminus \Sigma)$ is a minimizer of E over $H_0^1(\Omega \setminus \Sigma)$, then for every $x_0 \in \mathbb{R}^n$ and a.e. $r > 0$ one has*

$$\int_{B_r(x_0) \setminus \Sigma} |\nabla u|^2 dx = \int_{\partial B_r(x_0) \setminus \Sigma} u \frac{\partial u}{\partial \nu} d\mathcal{H}^{n-1} + \int_{B_r(x_0)} f u dx,$$

where $\frac{\partial u}{\partial \nu} := \nabla u \cdot \nu$, ν standing for the normal to $\partial B_r(x_0)$.

Proof. From the relationship

$$\int_{\Omega \setminus \Sigma} \nabla u \cdot \nabla \varphi dx = \int_{\Omega} f \varphi dx$$

for every $\varphi \in H_0^1(\Omega \setminus \Sigma)$, taking $\varphi(x) := g_\varepsilon(|x - x_0|)u(x)$, where $g_\varepsilon \in \text{Lip}(\mathbb{R}^+)$ be defined as

$$g_\varepsilon(x) := \begin{cases} 1, & x \leq r - \varepsilon, \\ 0, & x \geq r, \\ -\frac{1}{\varepsilon}(x - r), & r - \varepsilon < x < r \end{cases},$$

and $\varepsilon \in (0, r)$ is arbitrary, we get

$$\begin{aligned} \int_{\Omega \setminus \Sigma} |\nabla u|^2 g_\varepsilon(|x - x_0|) dx + \int_{\Omega \setminus \Sigma} u \nabla u \cdot g'_\varepsilon(|x - x_0|) \frac{x - x_0}{|x - x_0|} dx \\ = \int_{\Omega} f u g_\varepsilon(|x - x_0|) dx. \end{aligned} \quad (112)$$

Letting $\varepsilon \rightarrow 0^+$, we have

$$\begin{aligned} \int_{\Omega \setminus \Sigma} |\nabla u|^2 g_\varepsilon(|x - x_0|) dx &\rightarrow \int_{B_r(x_0) \cap \Omega \setminus \Sigma} |\nabla u|^2 dx \\ \int_{\Omega} f u g_\varepsilon(|x - x_0|) dx &\rightarrow \int_{B_r(x_0) \cap \Omega} f u dx, \end{aligned} \quad (113)$$

and

$$\begin{aligned}
\int_{\Omega \setminus \Sigma} u \nabla u \cdot g'_\varepsilon(|x - x_0|) \frac{x - x_0}{|x - x_0|} dx &= -\frac{1}{\varepsilon} \int_{(B_r(x_0) \setminus \bar{B}_{r-\varepsilon}(x_0)) \cap \Omega \setminus \Sigma} u \nabla u \cdot \frac{x - x_0}{|x - x_0|} dx \\
&= -\frac{1}{\varepsilon} \int_{r-\varepsilon}^r d\rho \int_{\partial B_\rho(x_0) \cap \Omega \setminus \Sigma} u \nabla u \cdot \frac{x - x_0}{\rho} d\mathcal{H}^{n-1} \\
&\quad \text{by coarea formula} \\
&\rightarrow \int_{\partial B_r(x_0) \cap \Omega \setminus \Sigma} u \frac{\partial u}{\partial \nu} d\mathcal{H}^{n-1}(x),
\end{aligned} \tag{114}$$

for a.e. $r > 0$, because the function

$$\rho \in (0, r) \mapsto \int_{\partial B_\rho(x_0) \setminus \Sigma} u \nabla u \cdot \frac{x - x_0}{\rho} d\mathcal{H}^{n-1}(x)$$

defined for a.e. $\rho \in (0, r)$ belongs to $L^1(0, r)$ for every $r > 0$. Now, plugging (113) and (114) into (112), we get the desired assertion. \square

References

- [1] Hans Wilhelm Alt, Luis A. Caffarelli, and Avner Friedman. Variational problems with two phases and their free boundaries. *Trans. Amer. Math. Soc.*, 282(2):431–461, 1984.
- [2] Luigi Ambrosio, Nicola Fusco, and Diego Pallara. *Functions of bounded variation and free discontinuity problems*. Oxford Mathematical Monographs. The Clarendon Press, Oxford University Press, New York, 2000.
- [3] Alexis Bonnet. On the regularity of edges in image segmentation. *Ann. Inst. H. Poincaré Anal. Non Linéaire*, 13(4):485–528, 1996.
- [4] Matthieu Bonnard, Antoine Lemenant, and Filippo Santambrogio. Approximation of length minimization problems among compact connected sets. *SIAM J. Math. Anal.*, 47(2):1489–1529, 2015.
- [5] Giuseppe Buttazzo, Edoardo Mainini, and Eugene Stepanov. Stationary configurations for the average distance functional and related problems. *Control Cybernet.*, 38(4A):1107–1130, 2009.
- [6] Giuseppe Buttazzo, Edouard Oudet, and Eugene Stepanov. Optimal transportation problems with free Dirichlet regions. In *Variational methods for discontinuous structures*, volume 51 of *Progr. Nonlinear Differential Equations Appl.*, pages 41–65. Birkhäuser, Basel, 2002.
- [7] Giuseppe Buttazzo, Aldo Pratelli, Sergio Solimini, and Eugene Stepanov. *Optimal urban networks via mass transportation*, volume 1961 of *Lecture Notes in Mathematics*. Springer-Verlag, Berlin, 2009.
- [8] Giuseppe Buttazzo and Filippo Santambrogio. Asymptotical compliance optimization for connected networks. *Netw. Heterog. Media*, 2(4):761–777, 2007.
- [9] Giuseppe Buttazzo and Eugene Stepanov. Optimal transportation networks as free Dirichlet regions for the Monge-Kantorovich problem. *Ann. Sc. Norm. Super. Pisa Cl. Sci. (5)*, 2(4):631–678, 2003.

- [10] Giuseppe Buttazzo and Eugene Stepanov. Minimization problems for average distance functionals. In *Calculus of variations: topics from the mathematical heritage of E. De Giorgi*, volume 14 of *Quad. Mat.*, pages 48–83. Dept. Math., Seconda Univ. Napoli, Caserta, 2004.
- [11] Guy David. *Singular sets of minimizers for the Mumford-Shah functional*, volume 233 of *Progress in Mathematics*. Birkhäuser Verlag, Basel, 2005.
- [12] Guy David. Local regularity properties of almost-and quasiminimal sets with a sliding boundary condition. *preprint*, 2015.
- [13] Guy David and Stephen Semmes. *Analysis of and on uniformly rectifiable sets*, volume 38 of *Mathematical Surveys and Monographs*. American Mathematical Society, Providence, RI, 1993.
- [14] Kenneth Falconer. *The geometry of fractal sets*, volume 85 of *Cambridge Tracts in Mathematics*. Cambridge University Press, Cambridge, 1986.
- [15] Yangqin Fang. *Ensembles minimaux, existence et régularité*. Thèse de l’université Paris-Sud, 2015.
- [16] Herbert Federer. *Geometric measure theory*. Die Grundlehren der mathematischen Wissenschaften, Band 153. Springer-Verlag New York Inc., New York, 1969.
- [17] David Gilbarg and Neil S. Trudinger. *Elliptic partial differential equations of second order*, volume 224 of *Grundlehren der Mathematischen Wissenschaften [Fundamental Principles of Mathematical Sciences]*. Springer-Verlag, Berlin, second edition, 1983.
- [18] Antoine Henrot and Michel Pierre. *Variation et optimisation de formes*, volume 48 of *Mathématiques & Applications (Berlin) [Mathematics & Applications]*. Springer, Berlin, 2005. Une analyse géométrique. [A geometric analysis].
- [19] Kazimierz Kuratowski. *Topologie. I et II*. Éditions Jacques Gabay, Sceaux, 1992. Part I with an appendix by A. Mostowski and R. Sikorski, Reprint of the fourth (Part I) and third (Part II) editions.
- [20] Koch Herbert, Leoni Giovanni and Morini Massimiliano. On optimal regularity of free boundary problems and a conjecture of De Giorgi. *Comm. Pure Appl. Math.*, 1051–1076, 2005.
- [21] Antoine Lemenant. A selective review on Mumford-Shah minimizers. *to appear in Bollettino UMI*.
- [22] Antoine Lemenant. On the homogeneity of global minimizers for the Mumford-Shah functional when K is a smooth cone. *Rend. Semin. Mat. Univ. Padova*, 122:129–159, 2009.
- [23] Antoine Lemenant. About the regularity of average distance minimizers in \mathbb{R}^2 . *J. Convex Anal.*, 18(4):949–981, 2011.
- [24] Antoine Lemenant. A presentation of the average distance minimizing problem. *Zap. Nauchn. Sem. S.-Peterburg. Otdel. Mat. Inst. Steklov. (POMI)*, 390(Teoriya Predstavlenii, Dinamicheskie Sistemy, Kombinatornye Metody. XX):117–146, 308, 2011.
- [25] Xin Yang Lu. Example of minimizer of the average-distance problem with non closed set of corners. *Rendiconti Mat. Padova*. in print.

- [26] Xin Yang Lu and Dejan Slepčev. Properties of minimizers of average-distance problem via discrete approximation of measures. *SIAM J. Math. Anal.*, 45(5):3114–3131, 2013.
- [27] Michele Miranda, Jr., Emanuele Paolini, and Eugene Stepanov. On one-dimensional continua uniformly approximating planar sets. *Calc. Var. Partial Differential Equations*, 27(3):287–309, 2006.
- [28] Emanuele Paolini and Eugene Stepanov. Qualitative properties of maximum distance minimizers and average distance minimizers in \mathbf{R}^n . *J. Math. Sciences (N.Y.)*, 122(3):105–122, 2004.
- [29] Emanuele Paolini and Eugene Stepanov. Existence and regularity results for the Steiner problem. *Calc. Var. Partial Differential Equations*, 46(3-4):837–860, 2013.
- [30] Filippo Santambrogio and Paolo Tilli. Blow-up of optimal sets in the irrigation problem. *J. Geom. Anal.*, 15(2):343–362, 2005.
- [31] Dejan Slepčev. Counterexample to regularity in average-distance problem. *Ann. Inst. H. Poincaré Anal. Non Linéaire*, 31(1):169–184, 2014.
- [32] Eugene Stepanov. Partial geometric regularity of some optimal connected transportation networks. *J. Math. Sci. (N. Y.)*, 132(4):522–552, 2006.
- [33] Vladimír Šverák. On optimal shape design. *J. Math. Pures Appl. (9)*, 72(6):537–551, 1993.
- [34] Paolo Tilli. Some explicit examples of minimizers for the irrigation problem. *J. Convex Anal.*, 17(2):583–595, 2010.
- [35] Paolo Tilli. Compliance estimates for two-dimensional problems with Dirichlet region of prescribed length. *Netw. Heterog. Media*, 7(1):127–136, 2012.
- [36] Paolo Tilli and Davide Zucco. Asymptotics of the first Laplace eigenvalue with Dirichlet regions of prescribed length. *SIAM Journal of Mathematical analysis*, 45:3266–3282, 2013.